

Power+ Speed drive

CAREL



ENG User manual

**LEGGI E CONSERVA
QUESTE ISTRUZIONI**

**READ AND SAVE
THESE INSTRUCTIONS**

  **NO POWER
& SIGNAL
CABLES
TOGETHER**

READ CAREFULLY IN THE TEXT!

Integrated Control Solutions & Energy Savings

WARNINGS



CAREL bases the development of its products on decades of experience in HVAC, on the continuous investments in technological innovations to products, procedures and strict quality processes with in-circuit and functional testing on 100% of its products, and on the most innovative production technology available on the market. CAREL and its subsidiaries nonetheless cannot guarantee that all the aspects of the product and the software included with the product respond to the requirements of the final application, despite the product being developed according to start-of-the art techniques. The customer (manufacturer, developer or installer of the final equipment) accepts all liability and risk relating to the configuration of the product in order to reach the expected results in relation to the specific final installation and/or equipment. CAREL may, based on specific agreements, acts as a consultant for the positive commissioning of the final unit/application, however in no case does it accept liability for the correct operation of the final equipment/system.

The CAREL product is a state-of-the-art product, whose operation is specified in the technical documentation supplied with the product or can be downloaded, even prior to purchase, from the website www.carel.com.

Each CAREL product, in relation to its advanced level of technology, requires setup / configuration / programming / commissioning to be able to operate in the best possible way for the specific application. The failure to complete such operations, which are required/indicated in the user manual, may cause the final product to malfunction; CAREL accepts no liability in such cases. Only qualified personnel may install or carry out technical service on the product. The customer must only use the product in the manner described in the documentation relating to the product. In addition to observing any further warnings described in this manual, the following warnings must be heeded for all CAREL products:

- prevent the electronic circuits from getting wet. Rain, humidity and all types of liquids or condensate contain corrosive minerals that may damage the electronic circuits. In any case, the product should be used or stored in environments that comply with the temperature and humidity limits specified in the manual;
- do not install the device in particularly hot environments. Too high temperatures may reduce the life of electronic devices, damage them and deform or melt the plastic parts. In any case, the product should be used or stored in environments that comply with the temperature and humidity limits specified in the manual;
- do not attempt to open the device in any way other than described in the manual;
- do not drop, hit or shake the device, as the internal circuits and mechanisms may be irreparably damaged;
- do not use corrosive chemicals, solvents or aggressive detergents to clean the device;
- do not use the product for applications other than those specified in the technical manual.

All of the above suggestions likewise apply to the controllers, serial boards, programming keys or any other accessory in the CAREL product portfolio.

CAREL adopts a policy of continual development. Consequently, CAREL reserves the right to make changes and improvements to any product described in this document without prior warning. The technical specifications shown in the manual may be changed without prior warning.

The liability of CAREL in relation to its products is specified in the CAREL general contract conditions, available on the website www.carel.com and/or by specific agreements with customers; specifically, to the extent where allowed by applicable legislation, in no case will CAREL, its employees or subsidiaries be liable for any lost earnings or sales, losses of data and information, costs of replacement goods or services, damage to things or people, downtime or any direct, indirect, incidental, actual, punitive, exemplary, special or consequential damage of any kind whatsoever, whether contractual, extra-contractual or due to negligence, or any other liabilities deriving from the installation, use or impossibility to use the product, even if CAREL or its subsidiaries are warned of the possibility of such damage.

DISPOSAL

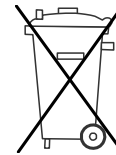

The product is made from metal parts and plastic parts. In reference to European Union directive 2002/96/EC issued on 27 January 2003 and the related national legislation, please note that:

1. WEEE cannot be disposed of as municipal waste and such waste must be collected and disposed of separately;
2. the public or private waste collection systems defined by local legislation must be used. In addition, the equipment can be returned to the distributor at the end of its working life when buying new equipment.
3. the equipment may contain hazardous substances: the improper use or incorrect disposal of such may have negative effects on human health and on the environment;
4. the symbol (crossed-out wheeled bin) shown on the product or on the packaging and on the instruction sheet indicates that the equipment has been introduced onto the market after 13 August 2005 and that it must be disposed of separately;
5. in the event of illegal disposal of electrical and electronic waste, the penalties are specified by local waste disposal legislation.

WARNING: Separate as much as possible the probe and digital input signal cables from the cables carrying inductive loads and power cables to avoid possible electromagnetic disturbance. Never run power cables (including the electrical panel wiring) and signal cables in the same conduits.



READ CAREFULLY IN THE TEXT!

Symbols:



Dangerous voltage



Caution, hot surface



Important: brings critical subjects regarding use of the product to the user's attention.



Note: when attention must be given to subjects of relevant importance, in particular regarding practical use of the various product functionality.

Contents

1.	Warnings	7
1.1	General warnings	7
1.2	Fundamental safety rules	7
2.	Introduction	7
2.1	Functions and main features	7
2.2	Models	7
3.	Installation	8
3.1	Identification	8
3.2	Structure	8
3.3	Dimensions	8
3.4	Drilling and assembly	8
3.5	Cooling	9
3.6	Electrical installation	9
3.7	Conformity to EMC standards	10
3.8	Electrical connections	10
3.9	Functional layouts	13
3.10	General connection diagram	14
4.	Start-up	15
4.1	Configuration	15
4.2	A – PM motor (brushless)	16
4.3	B – Asynchronous motor with vectorial control	17
4.4	C – Asynchronous motor with V/f control	17
4.5	Autotuning	17
4.6	Controls before commissioning	17
5.	Functions	19
5.1	Inputs and outputs	19
5.2	Relay configuration	19
5.3	Minimum and maximum output frequency	19
5.4	Direction of rotation inversion	19
5.5	Speed profile	19
5.6	Speed profile: execution method	20
5.7	Switching frequency	20
5.8	Stop mode	20
5.9	Flying restart	20
5.10	V/f control for asynchronous motor	20
5.11	Motor control on start-up	21
5.12	PI parameters	21
5.13	Commands	21
5.14	Status variables	22
5.15	Modbus® commands	22
6.	Protections	23
6.1	Skip frequency	23
6.2	Automatic reduction of the switching frequency	23
6.3	Automatic reduction of motor speed	23
7.	Parameters table	24
7.1	Commands	29
7.2	Status variables	29
8.	Alarms	33
8.1	Types of alarm	33
8.2	Alarms log	33
8.3	Alarms table	33
8.4	Modbus® communication error code	34
8.5	Motor overtemperature	34
8.6	Serial communication interruption	34
8.7	Alarms signal with relay	34
9.	Technical specifications	35
9.1	Rated current values	36
10.	Appendix	37
10.1	Conversion formulas	37
10.2	Conversion table	37



1 WARNINGS







1.1 General warnings

- The Power+ drive must be fitted by professionally qualified personnel on a complete unit or system as part of a fixed installation.
- This device features dangerous voltages, and consequently failure to observe the instructions contained in this user manual may cause serious harm to people and damage to things.
- The system design, installation, commissioning and maintenance of the drive are operations that are reserved solely for qualified personnel, who understand all of the safety warnings, installation, operating and maintenance instructions contained in this user manual code +0300050EN, available, including prior to purchase, at www.carel.com, under "Literature".

1.2 Fundamental safety rules

Before performing any maintenance work:

- disconnect Power+ and external control circuits from the power supply, moving the main system switch to "off";
- wait at least 5 minutes;
-  always check, using a suitable multimeter, that there is no dangerous voltage across the terminals;
-  always make sure the motor has stopped completely. Motors that are still freely rotating may produce dangerous voltages at the power+ terminals, even when this is disconnected from the power supply;

-  check the temperature of the heat sink: coming in contact with the heat sink may cause burns.
-  When Power+ is connected to the mains, motor terminals U, V, W are live, even if the motor is not running.
-  Do not measure insulation resistance or dielectric rigidity directly on Power+, or with Power+ connected.
-  The control terminals are isolated from the mains voltage. Nonetheless, the relay outputs may have a dangerous control voltage even when Power+ is not connected to the mains.
-  The level of safety provided by the enabling inputs on Power+ (excluding the "Safety Torque Off " input when used in compliance with the standards) is not sufficient in critical applications without adopting further independent safety measures. For all applications where malfunctions may cause serious harm to people and damage to things, the risks must be assessed and additional safety measures adopted
-  Observe all the general and local safety standards concerning installations of high voltage devices, as well as the regulations for the correct use of the personal protective equipment.
-  Use this device only for the purposes specified by the manufacturer. Do not make any modifications or replace any components unless recommended by the manufacturer, as these actions may cause fire, electric shock or other damage.

2 INTRODUCTION

Power+ is a drive designed to control compressors with sensorless-brushless permanent magnet (PM) motors (BLDC/BLAC) or asynchronous induction motors. For the latter, vector or V/f control can be selected. The drives can also be used in some applications with fans and pumps, and consequently the device offers flexible use in the air-conditioning and refrigeration sectors. It is fitted for panel installation or with heat sink outside of the panel. Configuration and programming, as well as the Run/stop controls and speed reference, are managed by a CAREL pCO controller or any BMS (Building Management System) via RS485 serial connection using the Modbus® protocol.

To suppress current harmonics:

- on single-phase models, during installation a toroidal coil, supplied with the drive, needs to be connected for active power factor correction (PFC);
- on three-phase models, connection of a DC choke is optional (available for purchase as an accessory), if compliance with EN61000-3-12 is required.

2.1 Functions and main features

In summary:

- compact dimensions for assembly in electrical panels;
- operation at ambient temperatures from -20 to 60°C;
- can be installed in residential and industrial environments;
- connection via serial network to Master programmable controller;
- network address can be configured by setting the dipswitches directly on the drive;
- can control various types of compressors;
- safety digital input (Safety Torque Off);
- dedicated input for PTC thermistor or thermostat to monitor motor overtemperature;
- panel installation or with heat sink outside of the panel, to optimize the dissipation of heat inside the electrical panel;

- electrical connections can be made without needing to remove the plastic cover;
- programmable acceleration curve to adapt to the required specifications when starting compressors;
- high switching frequency to limit motor noise;
- detailed information on drive status via numerous read-only variables;
- protection functions for the drive (short-circuit, overcurrent, earth fault, overvoltage and undervoltage on the bus, overtemperature), motor (overtemperature and limitation of current delivered) and system (Safety Torque Off input, communication failure).

2.2 Models

Code	Power supply	Nominal output current (A)	Physical size (*)
PSD0*10200**	200...240Vac ± 10%, 1~	10.5	1
PSD0*16200**	200...240Vac ± 10%, 1~	16	1
PSD0*14400**	380...480 Vac ± 10%, 3~	14.5/18	1
PSD0*22400**	380...480 Vac ± 10%, 3~	22.5	2

(*)For the dimensions see par. 3.3.

ACCESSORIES

Code	Code
PSACH10000	DC choke for PSD0*14400**
PSACH10100	DC choke for PSD0*22400**

3 INSTALLATION

! Important: avoid installing the drive in environments with the following characteristics:

- relative humidity higher than 90% or with condensation;
- strong vibrations or knocks;
- exposure to water sprays;
- exposure to aggressive and polluting atmospheres (e.g.: sulphur and ammonia fumes, saline mist, smoke) to avoid corrosion and/or oxidation;
- strong magnetic and/or radio frequency interference (thus avoid installation near transmitting antennae);
- exposure of the drive to direct sunlight and the elements in general.

3.1 Identification

Power+ is identified by a rating plate located on the top of the device, which describes the code, serial number, production date and revision number.

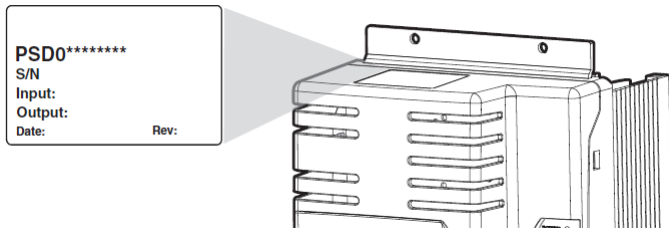

3.2 Structure



Ref.	Description
A	Terminal block for power connections
B	Terminal block for control connections
C	Fastening brackets
D	Cooling fan
E	PE
F	Microswitches for setting the network address
G	Operating status LED
H	Terminal block for PFC coil connection or optional DC choke

3.3 Dimensions

The overall dimensions of the drive vary based on the size of the heat sink (size 1 and size 2) and the type of assembly (panel or with heat sink outside of the panel, see the paragraph on "Drilling and assembly"), as the position of the fastening brackets affects the total height. The side brackets are only needed for assembly with the heat sink outside of the panel. For single-phase models, the dimensions increase because the coil for power factor control circuit (PFC) also needs to be connected. For three-phase models space may also be required for a DC choke for limiting the power factor (PFC). All the brackets have a 5.5 mm diameter hole.

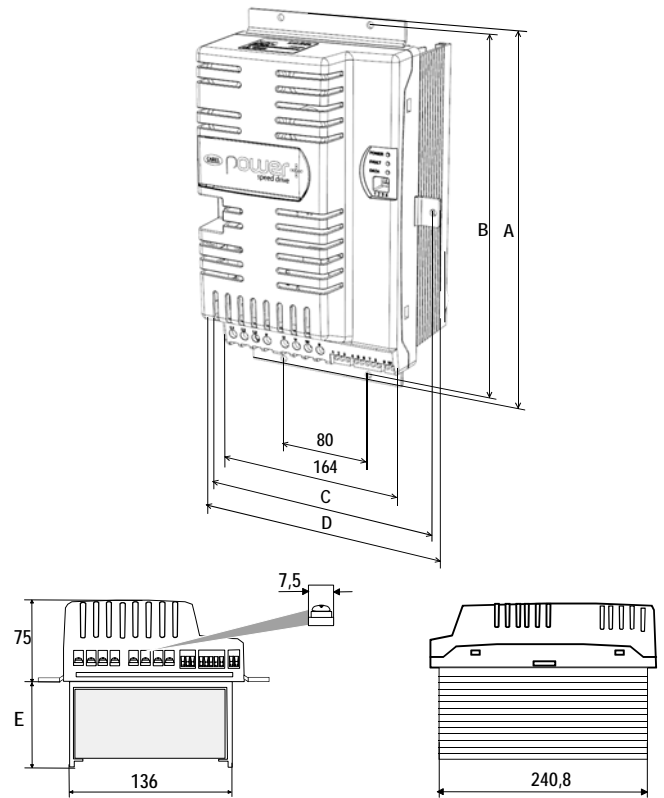

DIMENSIONS (mm)

Model / size	E	Heat sink outside panel				Panel	
		A	B	C	D	A	B
PSD0*10200**/ 1a	77	299,2	289,2	192,3	202,3	279,3	269,3
PSD0*16200**/ 1a	77	299,2	289,2	192,3	202,3	279,3	269,3
PSD0*14400** / 1	77	299,2	289,2	192,3	202,3	279,3	269,3
PSD0*22400** / 2	107,9	299,2	289,2	192,3	202,3	279,3	269,3

3.4 Drilling and assembly

For installation with the heat sink outside of the panel (Fig. 1), make a hole with dimensions of the dashed rectangle, where the heat sink will be fitted, and holes for fastening the brackets. These are inserted in the slots between the heat sink and the plastic cover. For panel installation (Fig. 2), only use the top and bottom brackets, which are inserted in the slots above and below the heat sink.

Installation with heat sink outside of the panel (fig.1)

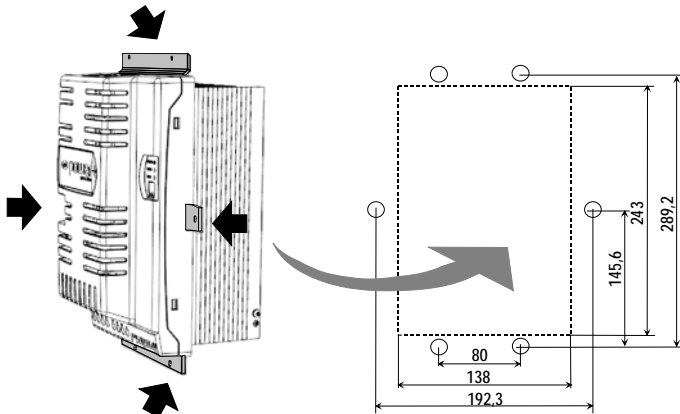

Panel installation (fig.2)

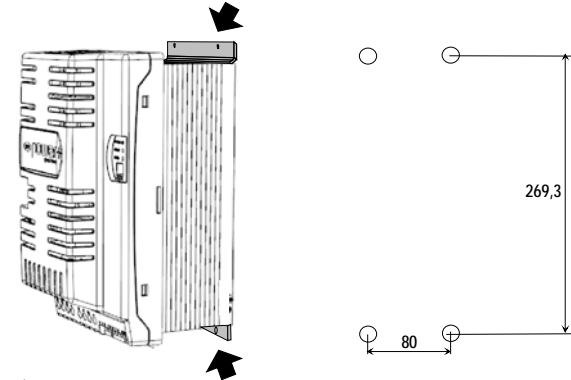

⚠ Important: in case of dismantling, do not grab the brackets, but rather the "solid" parts such as the heat sink and the plastic cover.

3.5 Cooling

All the Power+ drives are fitted with cooling fans. There must be sufficient air flow and air change inside the electrical panel. Refer to table 9.1 for maximum heat dissipation values.

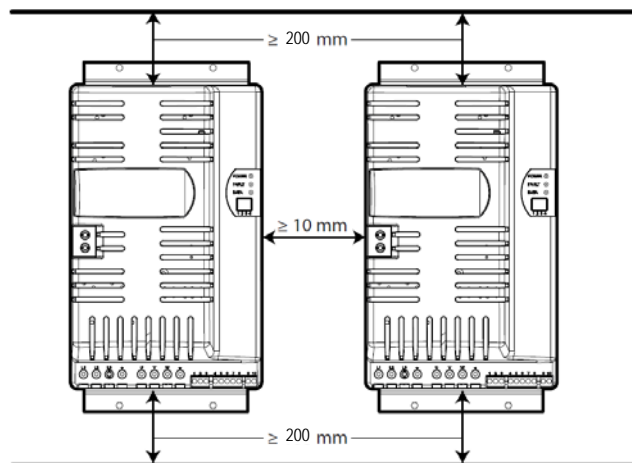

➡ Note:

- on single-phase models leave space to fit the PFC coil;
- on three-phase models space may be needed to fit a DC choke (see par. 3.8).

3.6 Electrical installation

Important:

⚠ before carrying out any maintenance work, disconnect the drive and the external control circuits from the power supply by moving the main system switch to "off ". Once power has been disconnected from the drive, wait at least 5 minutes before disconnecting the electrical cables;

⚠ always make sure the motor has stopped completely. Motors that are still freely rotating may produce dangerous voltages at the Power+ terminals, even when this is disconnected from the power supply.

Description of the terminals

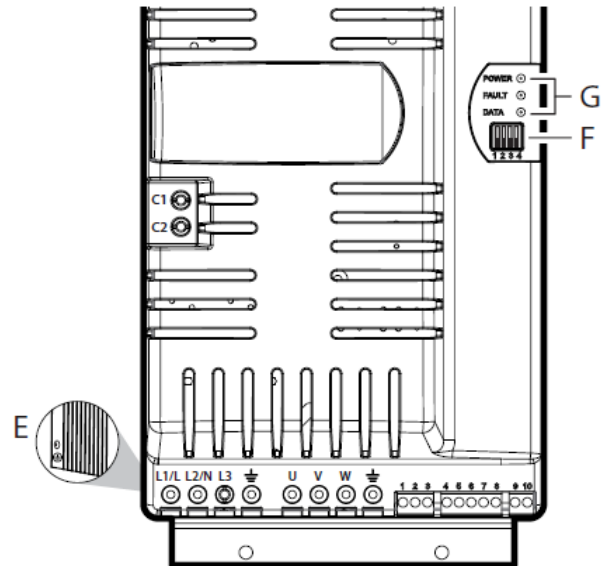

Ref.	Description										
L1/L, L2/N, L3 ⊥ earth connection (*)	Three-phase power supply input										
L1/L, L2/N ⊥ earth connection (*)	Single-phase power supply input										
U, V, W ⊥ earth connection (*)	Motor output										
C1, C2	Terminals for connecting the PFC coil for single-phase drives or optional DC choke for three-phase drives										
1	0V	RS485/ModBus® connection									
2	RX+/TX+										
3	RX-/TX-										
4	PTC Input										
5	24Vdc	Auxiliary voltage									
6	0V										
7	STOa	Safety Torque Off digital input (**)									
8	STOb										
9, 10	Relay output										
E	PE ⊥										
F	Microswitches for setting the network address										
G	Led	<table border="0"> <tr> <td>POWER</td> <td>=</td> <td>drive powered</td> </tr> <tr> <td>FAULT</td> <td>=</td> <td>active alarm</td> </tr> <tr> <td>DATA</td> <td>=</td> <td>communication active</td> </tr> </table>	POWER	=	drive powered	FAULT	=	active alarm	DATA	=	communication active
POWER	=	drive powered									
FAULT	=	active alarm									
DATA	=	communication active									

(*) The earth connections inside the drive are electrically connected together and to PE.

(**) To enable the drive for operation, apply a voltage of 24 Vac/Vdc to the Safety Torque Off digital input. The polarity is indifferent for direct current power supply.

Note: the control signals clamps unit 1...8 and the relay clamps unit 9, 10 are double isolated from each other and with respect to the power terminal board.

Important:

- in the European Union, all units that incorporate the drive must comply with the Machinery Directive 2006/42/EC. Specifically, the manufacturer of the unit is responsible for the installation of a main switch and the conformity to standard EN 60204-1;
- for fixed installations according to IEC61800-5-1, a disconnect device is required on the circuit between the power supply and the drive;
- only use permanently wired power input connections; the drive must be earthed: the earth wire must be sized for the maximum fault current that is normally limited by the fuses or a circuit breaker.

3.7 Conformity to EMC standards

Power+ is designed in compliance with the high EMC standards. All models are supplied with an internal EMC filter, designed to reduce the emissions taken towards the power supply line in conformity with harmonised European Standards. It is the installer's responsibility that the device or system within which Power+ is incorporated is in compliance with the Standards in force in the country of use. The Standard in force within the European Union is the EMC 2004/108/EC Directive. Power+ is intended to be incorporated inside fixed installation devices, only installed by specialised staff in all environments connected to the public network (EN61800-3 (2004) - 1st environment with restricted distribution; Category C2). Power+ can also be used in all environments powered with voltage < 1000V deriving from intermediate transformers (EN61800-3 (2004) -2nd environment; Category C3). Conformity with the EMC Standards is only guaranteed if the indications reported in the Electric connections paragraph are respected.

3.8 Electrical connections

For installation proceed as shown below, with reference to the general connection diagram (par. 3.10).

Power supply

Use cables rated to 90 °C, and if the temperature of the terminals exceeds 85 °C, use cables rated to 105 °C. Use cable terminals suitable for the terminals and the cables used. Loosen each screw and insert the cable ends, then tighten the screws and lightly tug the cables to check correct tightness. For fork cable terminals, do not exceed the maximum width shown in the figure.

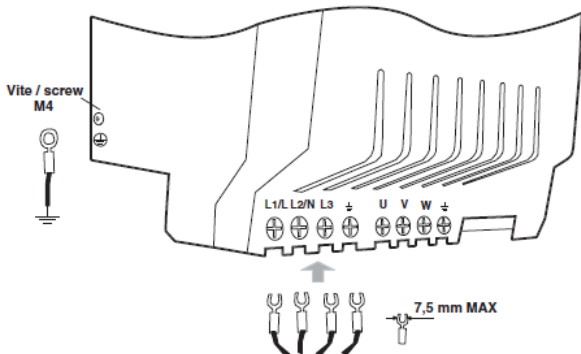

- Important:** the tightening torque is:
- power terminals: 1Nm;
 - control terminals: 0,5Nm.

The drive must be earthed: to do this, use either the screw terminal (earth symbol \perp), or the screw (PE symbol \oplus) on the side of the heat sink, in accordance with local standards in force. To minimise EMC problems, use a power cable with earth wire included, connected to terminal \perp . The power supply earth must be connected directly to the earth bar in the electrical panel, without branches to other devices; the earth wire size must be greater than or equal to the phase wires; the earth impedance must be compliant with national and local standards; in compliance with UL requirements, the protective earth connections (PE) must be made using eyelet lugs. On single-phase models, also connect the PFC coil. On three-phase models, where necessary connect the optional DC choke in place of the jumper that closes terminals C1 and C2. See the following paragraph. Connect the power cables: for single-phase models connect the power supply to terminals L1/L and L2/N, for three-phase models to terminals L1, L2, L3; for the size of the cables and the type of fuses, see the table in paragraph 9.1.

Important:

- do not connect the power supply to terminals U, V, W;
- make sure the voltage, frequency and number of phases in the power supply match the ratings of the specific model.

Terminals C1 and C2

Important:

The use of terminals C1 and C2 depends on the model and differs based on the type of power supply: single-phase or three-phase.

Models with 200/240 Vac single-phase power supply

Connect the PFC coil supplied with the drive to terminals C1 and C2.

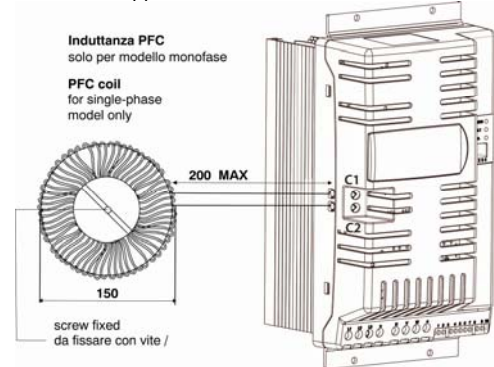

Important:

Never short-circuit terminals C1 and C2.

Models with 380/480 Vac three-phase power supply

There are two possible cases:

- 1) if compliance with EN61000-3-12 is required: connect the optional DC choke to terminals C1 and C2.

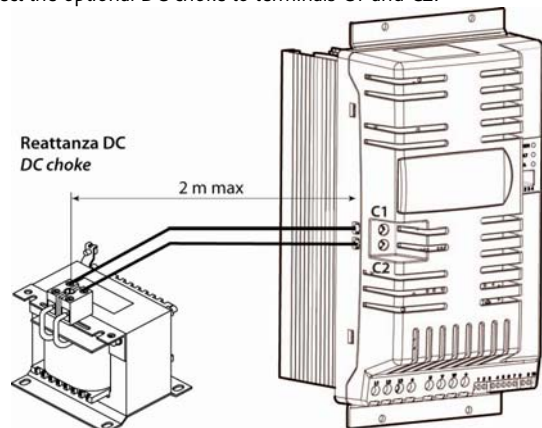

2) if compliance with EN61000-3-12 is not required: jumper terminals C1 and C2 (the drive leaves the factory with C1 and C2 jumpered).

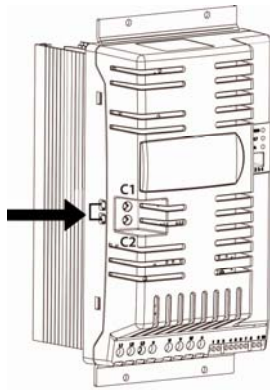

To connect the DC choke to terminals C1 and C2, use a cable that is the same size as the power cable. The maximum length of the cable must be 2 m.

The DC choke used depends on the size of the drive:

DC choke code	to be installed on Power+ drive	type
PSACH10000	PSD0014400	3mH, 20A
PSACH10100	PSD0022400	2mH, 25A

Earth leakage current

As for all inverter devices, earth leakage current may occur. The drive is designed to produce the minimum possible leakage current. The current depends on the length and the type of motor cable, the effective switching frequency, the type of earth connection used and the type of RFI filter installed.

If an ELCB (earth leakage circuit breaker) is to be used, the following conditions apply:

- it must be a type B device;
- it must be suitable to protect the equipment against leakage current with a DC component;
- Individual ELCBS should be used for each drive.

Motore

Connect the motor power cable: use four-wire cable, the impedance of the earth wire must be less than or equal to the impedance of the phase wires. For the size and maximum length of the cable according to the model, see the table in paragraph 9.1. To ensure conformity to the EMC directive, use shielded cable with the shield that covers at least 85% of the surface of the cable, with low impedance for high frequency signals. The cable can also be laid in steel and copper cableways.

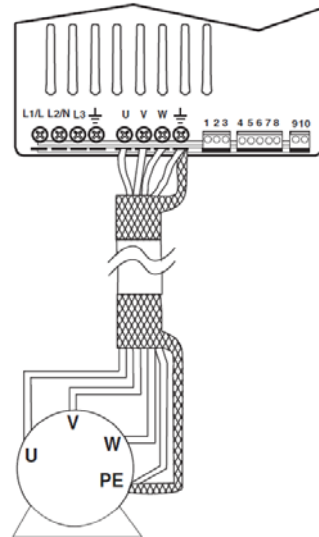

Connect the motor phases so as to ensure the required direction of rotation: to reverse direction, swap over two power wires on the drive power supply or motor.

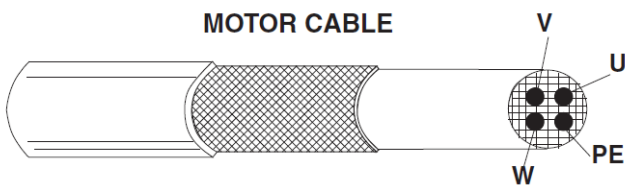
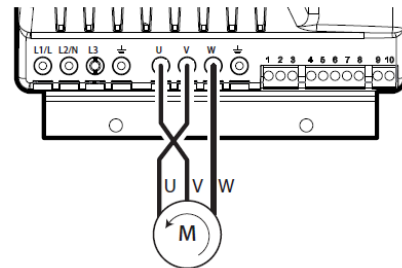
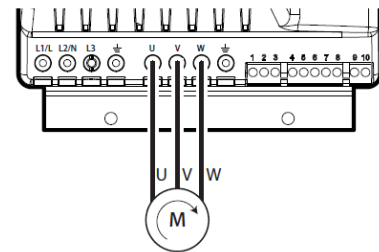

The shield is connected to both ends of the cable: the drive earth terminal should be connected by twisting the shield. The twisted part must be left as short as possible, and the length must not exceed five times the width. Earth the motor directly using the drive earth terminal.

Note: Most general purpose asynchronous motors are wound for operation on dual voltage supplies. This is indicated on the nameplate of the motor. This operational voltage is normally selected when installing the motor by selecting either Star or Delta connection. Star always gives the higher of the two voltage ratings. Typical ratings are:

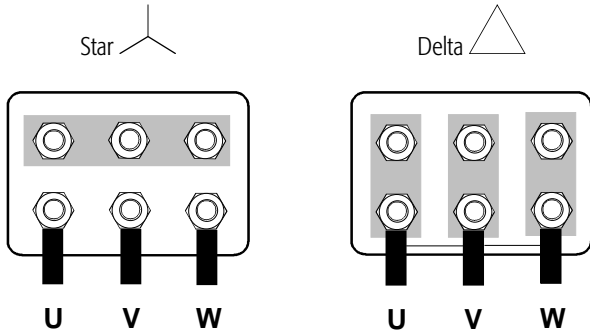
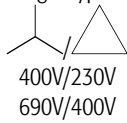

Important: do not turn on or OFF a switch between the drive and the motor when the drive is running.

Motor protector

Connect a PTC thermistor motor protector to terminals 4 and 5: use a cable with a minimum cross-section of 1 mm²; alternatively, a Klixon thermostat can be connected (see the general connection diagram). The PTC thermistor must be selected so that at activation temperature the resistance is >600 Ω.

Safety digital input

Connect the "Safety Torque Off " digital input to a safety device (for example, a maximum pressure switch) with normally closed voltage-free contact, in series with an external 24 Vac/24 Vdc voltage source, without needing to observe the polarity for direct current (ref. A). When the contact is open, the drive stops operating, bypassing the software control. If the Safety Torque Off function is not used, the input must be connected to the auxiliary 24 Vdc available on the terminal block, so as to enable correct operation of the drive (ref. B).

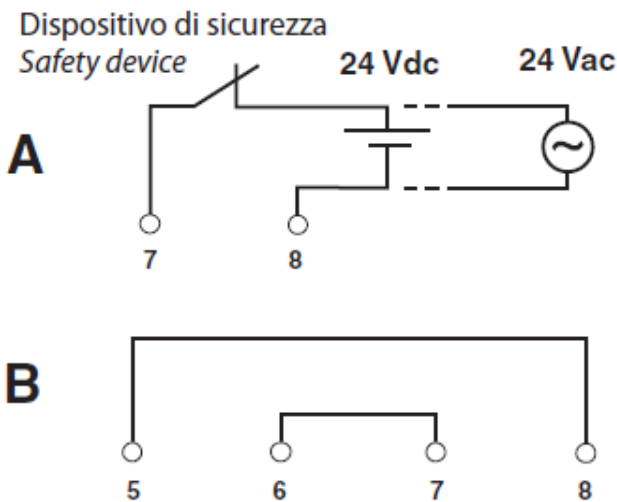

Note: TUV IEC61508 requires that the power supply applied to the safety input is isolated from the drive.

Serial network connection

For the serial connection use a three-wire shielded cable. For large networks, install a 120 ohm ¼. W resistor between terminals 2 and 3 on the last drive or device connected, to avoid possible communication problems.

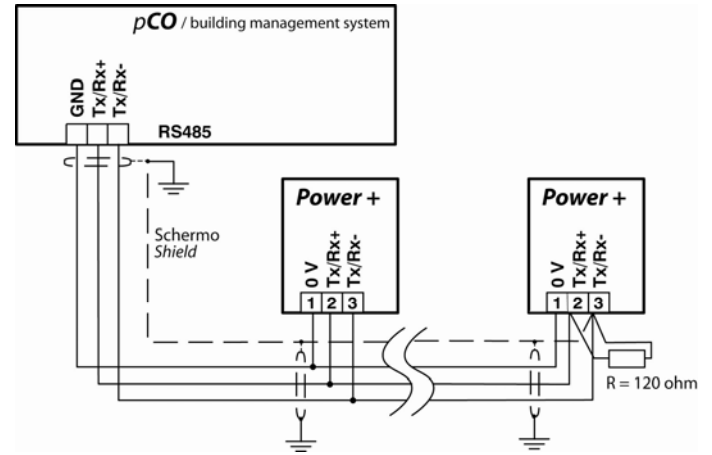

Important: the following warnings must be observed when connecting the drive:

- separate as much as possible the probe and digital input cables (at least 40 cm) from the power cables to avoid possible electromagnetic disturbance. Never lay power cables (including the electrical panel cables) and probe signal cables in the same conduits;
- the cables must be sized according to the table in paragraph 9.1;
- when the fuses are used, these must be chosen according to the data shown in the table in paragraph 9.1, and must comply with the national and local standards in force. In general, use type gG fuses for IEC and type T for UL, with a blow time less than 0.5 s;
- when a MCB is used, it must be of type B, rated according to the data shown in the table in paragraph 9.1;
- avoid installing cables connected to the control terminal block in the immediate vicinity of power devices (contactors, circuit breakers, etc.). Reduce the path of the cables as much as possible, and avoid spiral paths that enclose power devices.

3.9 Functional layouts

The functional layouts show the PFC inductance to be mounted only in the single-phase model and the DC choke where necessary fitted as an option on three-phase models only.

SINGLE-PHASE MODEL

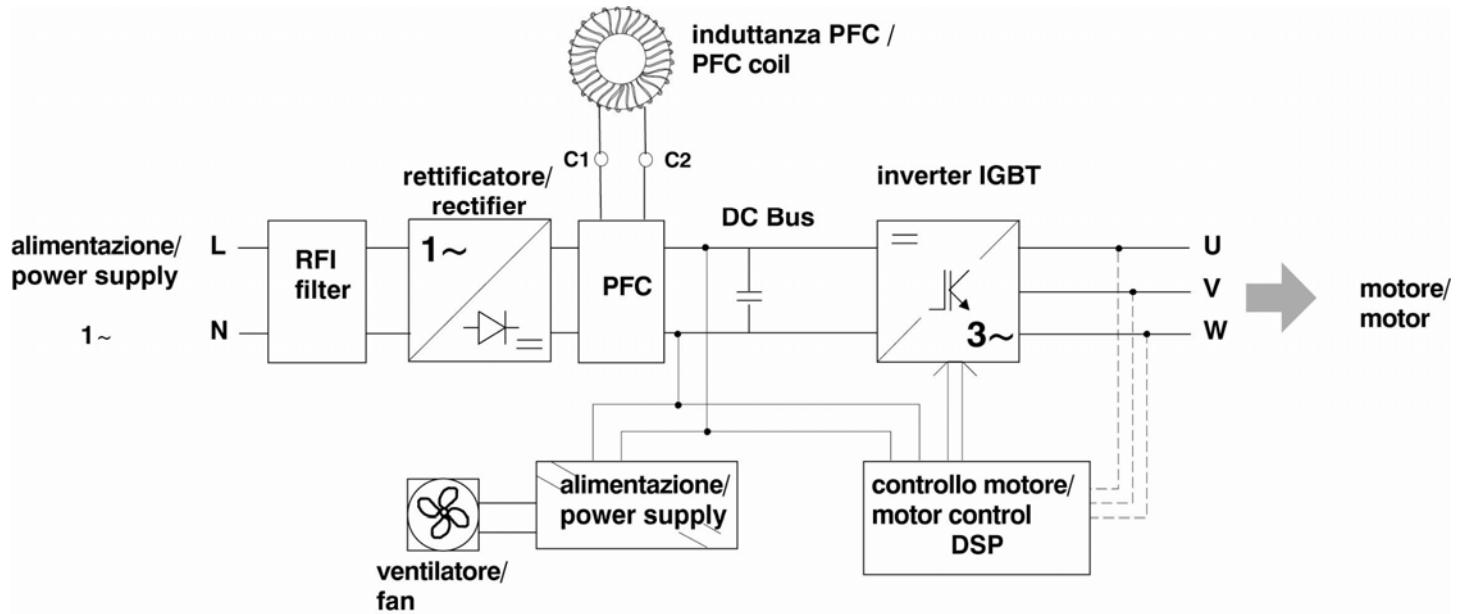

THREE-PHASE MODEL

Reattanza DC opzionale/
Optional DC choke

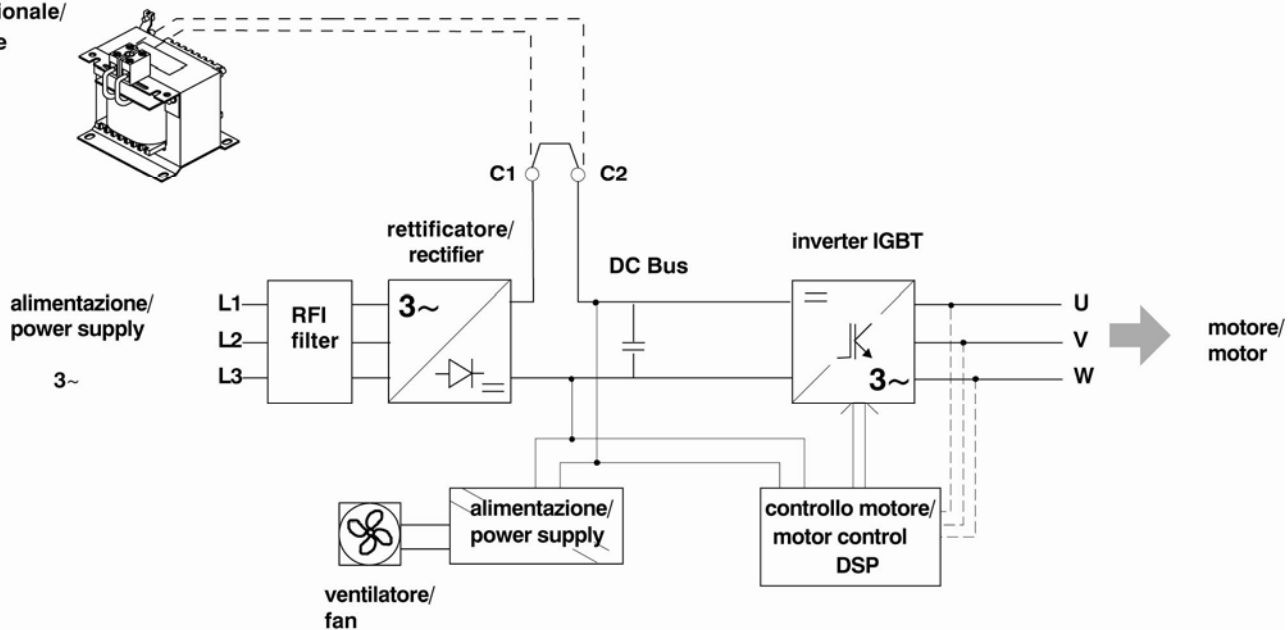

3.10 General connection diagram

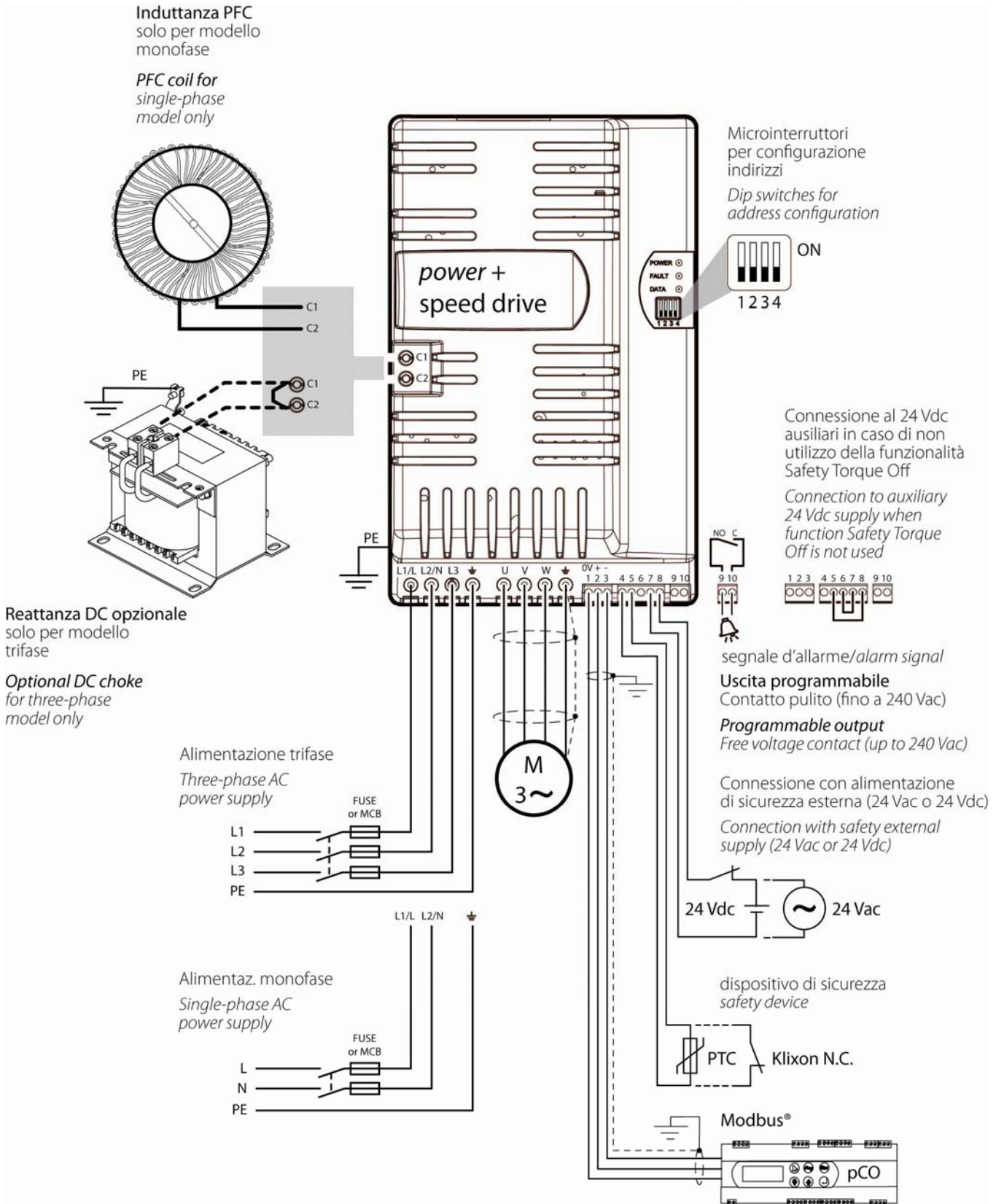

4 START-UP

⚠ Important: Power+ can pilot various types of compressors with permanent magnetic motors (PM) brushless BLDC/BLAC sensorless or asynchronous induction motors. To set the parameters of a particular compressor, consult the values indicated by CAREL in the document "Power+: compressors parameters tables", code +0300051IE, available, also prior to purchase, on the site www.carel.com.

4.1 Configuration

The configuration of the drive consists in setting the various types of parameters that regard:

- 1) the network communication: network address, data communication baudrate, data communication parity;
- 2) the selection of the type of motor control;
- 3) the motor plate data;
- 4) the motor electric data;
- 5) motor start-up;
- 6) the motor control in regenerative functioning mode (load deceleration with high inertia);
- 7) the proportional and integral regulation (PI) of the speed.

If the motor electric data (e.g.. resistances, inductance) are not known or are believed not to reflect the effective data (for example due to the length of the motor cable), the Autotuning function can be used. See paragraph 4.5.

➡ Note: once the communication parameters are set and the type of motor and control selected, the setting of the parameters of points 3...7 depends on the type of motor.

The address of the dip-switches in the drive is set manually as indicated below.

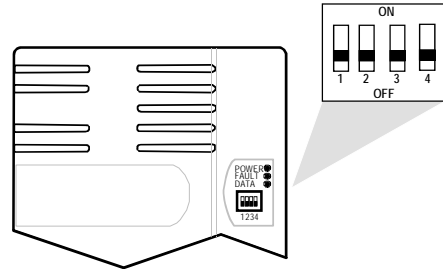

Dip-switch address

Dip-switches				Address
1	2	3	4	
OFF	OFF	OFF	OFF	0
ON	OFF	OFF	OFF	1
OFF	ON	OFF	OFF	2
...
ON	ON	ON	ON	15

⚠ Important: modify the network address via the dip-switches only with drive off.

4.1.1 Network communication

Network address

The configuration and the programming of the Power+ drive, as well as the run/stop commands and the speed reference are managed by a CAREL pCO control from any BMS (Building Management System) via RS485 serial connection with ModBus® protocol. The ModBus® network address that can be set from 1 to 247. This number is made up from the base address that can be set from the parameter and the address of the 4 dip-switches present on the drive, which goes from 0 to 15. By changing the base address in steps of 16, the entire interval can be covered.

Mod. add.	Description	Def	Min	Max	U.M.	R/W
32	Base address	1	1	232	-	R/W
121	Dip-switch address	0	1	15	-	R
120	Network address	1	1	247	-	R

⚠ Important: the drive only reads the network address on switch on or after a reset control.

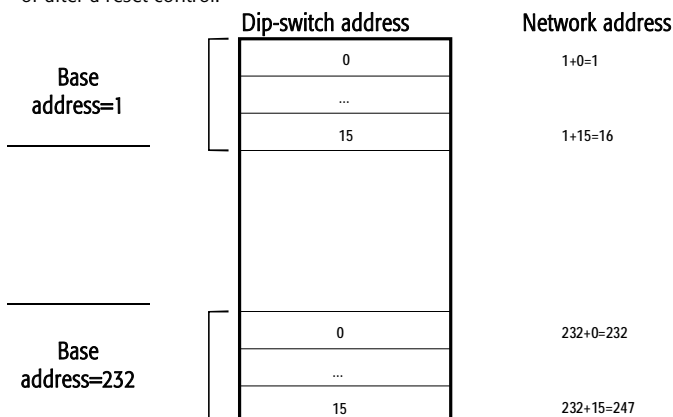

Communication baudrate/communication parity

The transmission speed can be selected between 9600 and 19200 bit/s. All devices connected in the serial network must have the same communication baudrate and the same data communication parity.

Mod. add.	Description	Def	Min	Max	U.M.	R/W
30	Data communication baudrate 0 = 9600 bit/s 1 = 19200 bit/s	1	0	1	-	R/W
31	Data communication parity 0 = none, 1 = even, 2 = odd	0	0	2	-	R/W

⚠ Important: the modification of the "Communication baudrate" and "Communication parity" parameters only becomes effective on the next switch on or reset command.

4.1.2 Motor control mode

Power+ allows to pilot compressors with permanent magnetic motors (PM) brushless BLDC/BLAC sensorless or asynchronous induction motors. For the latter it is possible to select between vectorial or V/f control.

Mod. add.	Description	Def	Min	Max	U.M.	R/W
0	Motor control mode 0 = PM brushless motor 1 = asynchronous motor with vectorial control 2 = asynchronous motor with V/f control	0	0	2	-	R/W

Below find the succession of parameters to be set according to the type of motor and control. Follow the steps described in paragraphs 4.2 or 4.3 or 4.4, on the basis of the type of motor control selected.

4.2 A - PM motor (brushless)

4.2.1 Motor data plate

Frequency/voltage/rated current/power factor

The base frequency is the frequency at which the maximum voltage is applied. The rated voltage is the maximum voltage applied to the motor. The rated current is the current at full load. The power factor is not used in this motor, but it is recommended to set it at 100 (=1.00) for future compatibility.

Mod. add.	Description	Def	Min	Max	U.M.	R/W
1	Motor base frequency	500	0	5000	0.1Hz	R/W
2	Motor base voltage	230/400	25	250/500	V	R/W
3	Motor rated current	Rat. Curr. drive output	(*)	(**)	0.1A	R/W
4	Motor power factor (cos(φ))	100(1.00)	0/50 (0.5)	100(1.0 0)	-	R/W

(*) Motor rated current : Min: PSD0*1440*: 36(3.6A); PSD0*2240*: 56(5.6A); PSD0*1020*: 0; PSD0*1620*: 0.

(**) Motor rated current : Max: PSD0*1440*: 180(18.0A); PSD0*2240*: 225(22.5A); PSD0*1020*: 105(10.5A); PSD0*1620*: 160(16.0A).

 **Note:** see the Appendix for the formulas that link the base frequency to the rpm, on the basis of the number of motor poles.

 **Important:** base frequency and rated voltage could also be relative to a generic point in the voltage/frequency given in the motor data sheet. In this case, pay attention to the fact that the base frequency is used as reference for the parameter:
- max frequency for starting current.

Maximum motor current

The maximum motor current in the case of the compressor must be set at 1000(=100.0%): as there is no necessity for quick accelerations, no peak currents must be envisioned.

Mod. add.	Description	Def	Min	Max	U.M.	R/W
5	Maximum output current	1000 (100.0%)	0	2000 (200.0%)	%Motor rated current	R/W

4.2.2 Motor electric data

The stator resistance is the resistance of the stator windings, measured between phase and phase.

In the mathematical model of the motor, Ld and Lq are the inductance used in the reference system (d,q) rotating at rotor speed.

It is recommended to use the values indicated by CAREL depending on the motors/compressors available. If the Autotuning is performed, these parameters are set automatically at the end of the procedure on the basis of the measurements detected.

Mod. add.	Description	Def	Min	Max	U.M.	R/W
46	Stator resistance	0	0	38500	0.001ohm	R/W
48	Stator inductance/Ld	0	0	6130	0.1mH	R/W
50	Lq inductance	0	0	6130	0.1mH	R/W

4.2.3 Motor start-up

These parameters optimise the initial start-up phase of the motor and the relative estimate of the position and the motor speed. It is recommended to use the values indicated by CAREL depending on the motors/compressors available. See paragraph 5.11 for the meaning of the parameters.

Mod. add.	Description	Def	Min	Max	U.M.	R/W
51	Magnetizing time	100	0	30000	ms	R/W
57	Starting current	10000 (100%)	0	1000 (100.0%)	%	R/W
58	Maximum frequency for starting current	0	0	1000 (100.0%)	%Motor rated frequency	R/W

4.2.4 Motor control in regenerative functioning mode

It is recommended to use the default values. Typically in the application with compressors, the regenerative functioning mode never occurs. For particular applications, consult CAREL.

Mod. add.	Description	Def	Min	Max	U.M.	R/W
53	Regeneration current limit	1000 (100.0%)	0	2000 (200.0%)	%Motor rated current	R/W
54	Overvoltage control current limit	100 (10.0%)	0	2000 (200.0%)	%Motor rated current	R/W

4.2.5 PI parameters for speed regulation

In applications with slow acceleration and deceleration times, as with compressors, it is recommended to use default values or the values indicated by CAREL depending on the motors/compressors available. For particular applications, consult CAREL.

Mod. add.	Description	Def	Min	Max	U.M.	R/W
55	Speed loop: Kp	250 (25.0%)	0	2000 (200.0%)	%	R/W
56	Speed loop: Ti	500(0.5)	1(0.001)	1000(1)	0.001s(s)	R/W

4.3 B - Asynchronous motor with vectorial control

4.3.1 Motor data plate

Frequency/voltage/rated current/power factor

The base frequency is the frequency at which the maximum voltage is applied. The rated voltage is the maximum voltage applied to the motor. If current peaks are necessary, the rated current of the motor must be lower enough than the drive rated current. The power factor is the rated $\cos(\varphi)$ of the motor.

Mod. add.	Description	Def	Min	Max	U.M.	R/W
1	Motor base frequency	500(50.0)	0	5000	0.1Hz	R/W
2	Motor base voltage	230/400	25	250/500	V	R/W
3	Motor rated current	Rat. Curr. drive output	(*)	(**)	0.1A	R/W
4	Motor power factor ($\cos(\varphi)$)	100 (1.00)	0/50 (0.5)	100 (1.00)	-	R/W

(*) Motor rated current : Min: PSD0*1440*: 36(3.6A); PSD0*2240*: 56(5.6A); PSD0*1020*: 0; PSD0*1620*: 0.

(**) Motor rated current : Max: PSD0*1440*: 180(18.0A); PSD0*2240*: 225(22.5A); PSD0*1020*: 105(10.5A); PSD0*1620*: 160(16.0A).

 **Note:** see the Appendix for the formulas that link the base frequency to the rpm, on the basis of the number of motor poles.

Maximum motor current

If current peaks are necessary, set the "out current max" a value equivalent to the drive rated current.

Mod. add.	Description	Def	Min	Max	U.M.	R/W
5	Maximum output current	1000(100.0%)	0	2000 (200.0%)	%Motor rated current	R/W

4.3.2 Motor electric data

They are values that are difficult to trace in the motors datasheets. It is recommended to use the values indicated by CAREL depending on the motors/compressors available. If the Autotuning is performed, these parameters are set automatically at the end of the procedure on the basis of the measurements detected.

Mod. add.	Description	Def	Min	Max	U.M.	R/W
45	Motor magnetizing current	0	0	Rated output current	0.1A	R/W
46	Stator resistance	0	0	38500	mΩ	R/W
47	Rotor resistance	0	0	38500	mΩ	R/W
48	Stator inductance/Ld	0	0	6130	0.1mH	R/W
49	Leakage factor	0	0	250(0.25)	-	R/W

4.3.3 Motor start-up

These parameters optimise the initial start-up phase of the motor and the relative estimate of the position and the rotor speed. It is recommended to use the values indicated by CAREL depending on the motors/compressors available.

Mod. add.	Description	Def	Min	Max	U.M.	R/W
51	Magnetizing time	100	0	30000	ms	R/W
57	Starting current	1000 (100.0%)	0	1000 (100.0%)	%	R/W
58	Maximum frequency for starting current	0	0	1000 (100.0%)	%Motor rated frequency	R/W

4.3.4 Motor control in regenerative functioning mode

It is recommended to use the default values. Typically in the applications with compressors, the regenerative functioning mode never occurs. For particular applications, consult CAREL.

Mod. add.	Description	Def	Min	Max	U.M.	R/W
53	Regeneration current limit	1000 (100.0%)	0	2000 (200.0%)	%Motor rated current	R/W
54	Overvoltage control current limit	100 (10.0%)	0	2000 (200.0%)	%Motor rated current	R/W

4.3.5 PI parameters for speed regulation

In applications with slow acceleration and deceleration times, as with compressors, it is recommended to use default values or the values indicated by CAREL depending on the motors/compressors available. For particular applications, consult CAREL.

Mod. add.	Description	Def	Min	Max	U.M.	R/W
55	Speed loop: Kp	250 (25.0%)	0	2000 (200.0%)	%	R/W
56	Speed loop: Ti	500(0.5)	1(0.001)	1000(1)	0.001s(s)	R/W

4.4 C - Asynchronous motor with V/f control

4.4.1 Motor data plate

Frequency/voltage/rated current/power factor

The base frequency is the frequency at which the maximum voltage is applied. The rated voltage is the maximum voltage applied to the motor. If current peaks are necessary, the rated current of the motor must be lower enough than the drive rated current. The Power factor is the rated $\cos(\varphi)$ of the motor.

Mod. add.	Description	Def	Min	Max	U.M.	R/W
1	Motor base frequency	500	0	5000	0.1Hz	R/W
2	Motor base voltage	230/400	25	250/500	V	R/W
3	Motor rated current	Rat. Curr. drive output	(*)	(**)	0.1A	R/W
4	Motor power factor $\cos(\varphi)$	100(1.00)	0/50 (0.5)	100 (1.00)	-	R/W

(*) Motor rated current : Min: PSD0*1440*: 36(3.6A); PSD0*2240*: 56(5.6A); PSD0*1020*: 0; PSD0*1620*: 0.
 (**) Motor rated current : Max: PSD0*1440*: 180(18.0A); PSD0*2240*: 225(22.5A); PSD0*1020*: 105(10.5A); PSD0*1620*: 160(16.0A).

 **Note:** see the Appendix for the formulas that link the base frequency to the rpm, on the basis of the number of motor poles.

4.4.2 Motor electric data

No parameter has to be set. If Autotuning is performed, the "stator resistance" parameter is set automatically at the end of the Autotuning procedure on the basis of the measurements detected, also if its value is not used.

Mod. add.	Description	Def	Min	Max	U.M.	R/W
46	Stator resistance	0	0	38500	mΩ	R/W

4.4.3 Motor start-up

Mod. add.	Description	Def	Min	Max	U.M.	R/W
35	V/f boost voltage	0	0	250 (25.0%)	%Motor base voltage	R/W
36	V/f frequency adjustment	0	0	1000 (100.0 %)	%Motor rated frequency	R/W
37	V/f voltage adjustment	0	0	1000 (100.0 %)	%Motor base voltage	R/W

These parameters optimise the initial start-up phase of the motor by adapting the V/f feature on the basis of the particular application, in order to improve performance at low speeds.

 **Note:** In the case of asynchronous motor with V/f control, the parameters lose meaning for the control of the motor in regenerative functioning mode and the PI parameters for the speed control.

4.5 Autotuning

Autotuning consists in a measurement cycle, which can last about 1 minute, at the end of which the **electric data** of the motor are measured and memorised in the respective parameters. To perform Autotuning, set the "Autotuning" parameter at 1. At the end, the parameter is automatically zeroed. The type of measure and the values memorised depend on the type of motor control selected. See the following tables. If this is unsuccessful, check the alarm 15. It is therefore necessary to repeat the procedure or search for the data requested in order to introduce them directly.

Mod. add.	Description	Def	Min	Max	U.M.	R/W
103	Autotuning 0/1=not active/start	0	0	1	-	R/W

Below a summary table with the electric data estimated according to the type of motor. Where indicated at the end of the procedure, the parameters are set at zero (0).

Mod. add.	Description	PM Brushless	Asynchronous vect.	Asynchronous V/f
45	Motor magnetizing current	NO(0)	YES	NO
46	Stator resistance	YES	YES	YES
47	Rotor resistance	NO(0)	YES	NO
48	Stator inductance/Ld	YES, Ld	YES, Ls	NO
49	Leakage factor	NO(0)	YES	NO
50	Lq inductance	YES	NO(0)	NO

Important:

- Autotuning can only be performed on a motor that is connected. At the start of the procedure, the motor must be at a standstill;
- the end of the Autotuning procedure is signalled by the "Autotuning" parameter and from bit7 of the "Status register", which are automatically taken back to 0.

4.6 Controls before commissioning

Before commissioning, check that:

- the drive output current is greater than or equal to the rated current or the maximum envisioned for the motor;
- the work voltage range is correct
- the section of the power supply cables is correct;
- the maximum section and length of the motor cables is correct and that they are connected in compliance with the wiring diagrams;
- all of the control inputs are connected correctly.

5 FUNCTIONS

5.1 Inputs and outputs

Inputs

The inputs include:

- 1) the single or three-phase power supply, depending on the model, which must be connected selecting suitable cables and fuses according to the table in paragraph 9.1;
- 2) the "Safety Torque Off" safety digital input, to which an alternating or direct voltage source is connected along with a safety device. See the main connection layout;
- 3) the PTC thermistor for motor overtemperature protection. Must be selected for motor protection and in a way that at the alarm temperature the resistance is > 600 ohm.

⚠ Important: in order to use the PTC input, the motor overtemperature alarm must be enabled. See the "Alarms" chapter.

Outputs

The drive outputs include:

- 1) the motor output, to which the cables must be connected, which are dimensioned according to the table in paragraph 9.1;
- 2) the relay output.

5.2 Relay configuration

The relay function can be programmed and can indicate a functioning condition of the drive or an alarm. See the "Alarms" chapter for the latter case. The relay contact closes if the corresponding event occurs.

Mod. add.	Description	Def	Min	Max	U.M.	R/W
26	Relay configuration 0: drive in alarm 1: fan control 2: drive overtemperature alarm 3: motor overtemperature alarm 4: motor overload alarm 5: overvoltage alarm 6: undervoltage alarm 7: speed derating in progress 8: motor run	0	0	8	-	R/W

5.3 Minimum and maximum output frequency

The parameters allow to set the minimum and maximum limit for the drive output frequency. The frequency set point must also be within the limits fixed by minimum and maximum frequency, otherwise it is not accepted.

Mod. add.	Description	Def	Min	Max	U.M.	R/W
6	Maximum output frequency	0	0	5000	0.1Hz	R/W
7	Minimum output frequency	0	0	5000	0.1Hz	R/W

5.4 Direction of rotation inversion

During drive commissioning, in order to change the direction of rotation of the motor, it is possible to exchange the two power supply wires on the drive side or motor side. In the event of application with compressors, there is only one motor rotation direction. In other cases it is possible also to enable the reverse direction of rotation with the relative parameter.

Mod. add.	Description	Def	Min	Max	U.M.	R/W
8	Reverse speed enable 0/1 = no/yes	0	0	1	-	R/W

5.5 Speed profile

Power+ has been designed with a programmable speed profile for adaptation to the features requested on compressor start-up. Once the speed profile has been selected it is also possible to establish the method of execution. The profile is designed by three frequencies (f_1, f_2, f_3), which must be reached with three linear ramp trends, defined via three accelerations (a_1, a_2, a_3). Once the frequency f_i ($i=1, 2, 3$) has been reached, the frequency value remains for the time t_i ($i=1, 2, 3$). Regarding decrease in speed, it is possible to set just one deceleration.

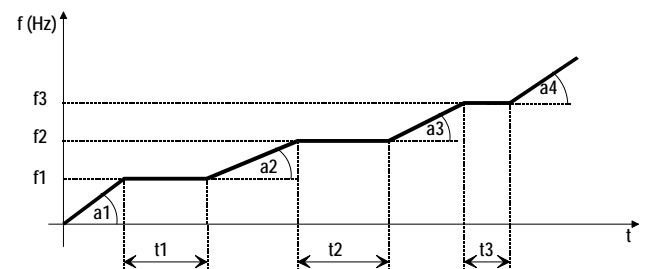

Key

$f_1 / f_2 / f_3$	Frequency 1/2/3	f	Frequency
$a_1/a_2/a_3/a_4$	Acceleration 1/2/3/4	t	Time
$t_1 / t_2 / t_3$	Delay 1/2/3		

Mod. add.	Description	Def	Min	Max	U.M.	R/W
12	Speed profile: frequency 1	0	0	5000	0.1Hz	R/W
13	Speed profile: frequency 2	0	0	5000	0.1Hz	R/W
14	Speed profile: frequency 3	0	0	5000	0.1Hz	R/W
15	Speed profile: acceleration 1	60	0	500	0.1Hz/s	R/W
16	Speed profile: acceleration 2	60	0	500	0.1Hz/s	R/W
17	Speed profile: acceleration 3	60	0	500	0.1Hz/s	R/W
18	Speed profile: acceleration 4	60	0	500	0.1Hz/s	R/W
19	Speed profile: stand-by time 1	0	0	600	s	R/W
20	Speed profile: delay 2	0	0	600	s	R/W
21	Speed profile: delay 3	0	0	600	s	R/W
23	Speed profile: deceleration	60	0	500	0.1Hz/s	R/W



Note: it is recommended to use the values indicated by CAREL in relation to the compressor used, as they guarantee the functioning mode specified by the manufacturer. Alternatively it is possible to set a simple profile ($f_2=f_3=F_{max}$; $t_1=t_2=t_3=0$; $a_2=a_3=a_4$ =maximum acceleration allowed) and refer management of the accelerations and delay times to the external control. However, in this case it is necessary to keep the values of a_1 and f_1 indicated by CAREL, as they are critical for the compressor start-up phase.

Mod. add.	Description	Def	Min	Max	U.M.	R/W
108	Motor frequency	-	-	-	0.1Hz	R
125	Pre-ramp frequency set point	-	-	-	0.1Hz	R
126	Post-ramp frequency set point	-	-	-	0.1Hz	R

Mod. add.	Description			Def	Min	Max	U.M.	R/W
22	Speed profile: execution method (2 bit parameter)			3	0	3	-	R/W
	bit	meaning	0/1					
	0	delay execution	always/only once at every start-up					
	1	force frequency 2	no/at start-up					

5.6 Speed profile: execution method

It is possible to define the execution method of the speed profile with bit0, i.e. if the individual delays must be performed just one time or if they must be carried out every time the frequency set point exceeds one of the f1, f2, f3 frequencies. If the frequency set point is decreased, the

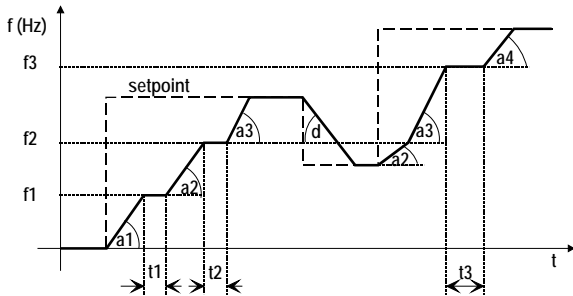

Key

f1/ f2/ f3	Characteristic frequency 1/2/3	d	Deceleration
a1/a2/a3/a4	Acceleration 1/2/3/4	f	Frequency
t1/ t2/ t3	Delay 1/2/3	t	Time

deceleration set is respected.

Note: if the bit0=1 and the frequency set point is between frequency 2 and frequency 3, the speed profile will be performed respecting delays t1 and t2. If the frequency set point successively decreases to a value below f2, the frequency is reached with the deceleration defined at the

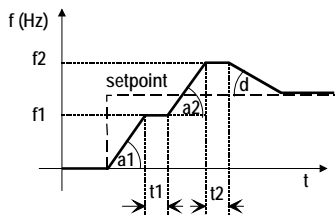

Key

f1/ f2	Frequency 1/2	f	Frequency
a1/a2	Acceleration 1/2	t	Time
t1/ t2	Delay 1/2	d	Deceleration

relative parameter. If the frequency set point finally increases to a frequency value greater than f3, only delay t3 is respected.

The bit1 is considered only if the frequency set point on start-up is lower than frequency 2 of the profile. If bit1=1, frequency 2 is always reached on start-up respecting delays t1 and t2. The frequency set point is then reached with the deceleration defined by the relative parameter.

Note: during execution of the acceleration/deceleration ramps, it is possible to display the current frequency of the motor and the intermediate pre-ramp and post-ramp set points.

5.7 Switching frequency

The parameter allows to set the switching frequency of the IGBT (Insulated Gate Bipolar Transistor). During functioning the switching frequency can decrease to protect the drive from overheating. It can be displayed with the operating switching frequency. See the "Protections" chapter.

Mod. add.	Description	Def	Min	Max	U.M.	R/W
24	Switching frequency 0 = 4kHz, 1 = 6kHz, 2 = 8kHz	0	0	2	-	R/W
124	Operating switching frequency 0=4kHz, 1=6kHz, 2= 8kHz	-	0	2	-	R

5.8 Stop mode

The motor stops after the Stop command has been given (see "Commands" paragraph). In the ramp stop the speed of the motor decreases according to the fixed deceleration parameter. In stop due to inertia, the motor stops without any control by the drive.

Mod. add.	Description	Def	Min	Max	U.M.	R/W
33	Stop mode 0 = ramp 1 = coast	1	0	1	-	R/W

5.9 Flying restart

Power+ has the speed hitch function, useful whenever the RUN command is given with motor rotating. Once the rotation frequency has been identified, the output frequency will be increased/decreased to the frequency set point on the basis of the established acceleration/deceleration parameters.

Mod. add.	Description	Def	Min	Max	U.M.	R/W
34	Flying restart 0/1=no/yes	0	0	1	-	R/W

5.10 V/f control for asynchronous motor

In the V/f control, the motor voltage varies linearly with the frequency in the flow area constant from 0 Hz to the point where the rated voltage is applied to the motor.

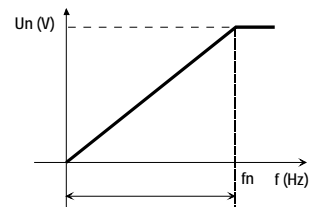

Key

Un	rated voltage	fn	Rated frequency
----	---------------	----	-----------------

The curve can be programmed, by inserting:

- 1) an increase in starting torque. The boost voltage is applied at frequency 0 for the time set at the "Magnetizing time" parameter, to then drop to zero in correspondence with the frequency adjustment.
- 2) a programmable adjustment point, to adapt the application curve better.

Mod. add.	Description	Def	Min	Max	U.M.	R/W
35	V/f boost voltage	0	0	250 (25.0)	% Motor base voltage	R/W
36	V/f freq.cy adjustment	0	0	1000 (100.0)	%Motor base frequency	R/W
37	V/f voltage adjustment	0	0	1000 (100.0)	% Motor base voltage	R/W

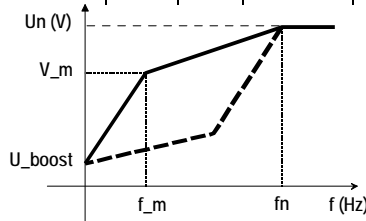

Key

f _n	Rated voltage	U _n	Rated voltage
f _m	Intermediate frequency	V _m	Intermediate voltage
U _{boost}	Voltage boost	f	Frequency

5.11 Motor control on start-up

To increase torque on start-up, Power+ envisions:

1) for PM brushless motors and for asynchronous motors with vectorial control, a start-up current for the magnetizing time at frequency 0 and then to the frequency defined at the "Maximum frequency for starting current" parameter. The value of the start-up current is defined by the following formulas.

START-UP CURRENT

PM brushless motor	Asynchronous motor with vectorial control
(Motor rated current)* *(Starting current)	(Magnetizing current)* *(100+Starting current)

Mod. add.	Description	Def	Min	Max	U.M.	R/W
45	Motor magnetizing current	0	0	Rated output current	0.1A	R/W
51	Magnetizing time	100	0	30000	0.001s	R/W
57	Starting current	0	0	1000 (100.0%)	%	R/W
58	Max frequency for starting current	0	0	1000 (100.0%)	%Motor base frequency	R/W

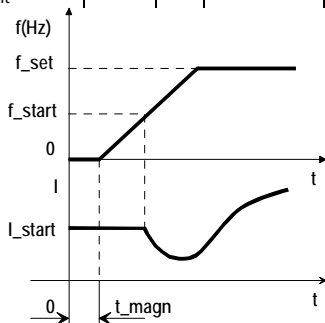

Key

f _{set}	Frequency set point	f _{start}	Max frequency for starting current
t _{magn}	Magnetizing time	I _{start}	Start-up current
t	Time	f	Frequency
I	Current		

2) for asynchronous motor with V/f control: see the "V/f control for asynchronous motor" paragraph.

5.12 PI parameters

Speed regulation takes place via a PI type control, which in its simplest form is characterised by the following law:

$$u(t) = K_p \left(e(t) + \frac{1}{T_i} \int e(t) dt \right)$$

Note that the control is calculated as the sum of the two separate contributions, proportional and integral:

- the proportional action varies the control action proportionally to the error. Therefore the greater the value of K_p (proportional gain) the faster will be the response speed. The proportional action, alone, does not allow the set point to be reached.
- the integral action varies the control action proportionally to the area of the error. The lower the T_i (integral time) value, the more energetic the control action. Moreover, the PI control tends to annul the error.

Mod. add.	Description	Def	Min	Max	U.M.
55	Speed loop: K _p	250(25.0)	0	2000(200.0)	%
56	Speed loop: T _i	500	1	1000	ms

5.13 Commands

1) Run/stop:

bit0: run control (Run=1) and stop control (stop=0) of the motor;
bit1: setting the direction of rotation, clockwise (0) or anti-clockwise (1). In order to have anti-clockwise rotation this must be previously enabled with the "Reverse speed enable" parameter.

2) Reset:

bit0: allows to cancel the alarms present in the alarms queue and to update the address communication, data communication parity and communication baudrate parameters. For example, the command must be given after modification of the dip-switches in order to set the network address.

bit1: allows to set the parameters at factory value (default). When the operation has taken place, the "Parameter default" alarm occurs. See the alarms table.

bit2: reset flag check drive switch on and switch off (see speed register, bit2)

Note: the resets take place on transition of the respective bit from zero to one and therefore it is necessary to take the bit at zero in order to allow a successive reset action.

3) Frequency set point it is the set point that the motor must reach following the "Run" command; the direction of rotation is given by the bit1 of the Run/Stop command.

4) Autotuning: the command is given after having set the motor plate data, if electric data is not available (resistances, inductance) of the specific motor. When autotuning has ended, the parameter 104 goes automatically back to zero. See the "Start-up" chapter.

Mod. add.	Description	Def.	Min	Max	U.M.
100	Run/Stop (2 bit parameter)	0	0	4	-
	bit meaning				
	0 0/1= stop/run				
1 0/1=rotation in clockwise/anticlockwise direction					
101	Reset (3 bit parameter)	0	0	7	-
	bit meaning				
	0 1= alarms reset and updating of communication parameters				
	1 1= parameters reset at default values				
2 1= reset flag check drive switch on and switch off (see speed regulator, bit2)					
102	Frequency set point	0	Min out freq.	Max out freq.	0.1Hz
103	Autotuning 0/1=not active/start	0	0	1	-

5.14 Status variables

The status variables are the read-only type and supply information regarding the status of the drive (e.g. Modbus® = 104, drive in start, stop or alarm) or the alarms present in the alarms code or other general information. For example, with the bit of the status regulator it is possible to know whether the drive is in a particular alarm status or protection, the status of the digital safety input (STO) or the relay output.

The speed register signals whether the speed profile has been completed, if the speed automatic decrease function is active and with the relative flag shows whether there has been a voltage black-out.

Other status variables inform regarding the drive temperature, current/voltage/power supplied, the energy supplied in kWh and MWh, the voltage and the voltage ripple on the DC bus, the number of drive switch-on hours and the number of functioning hours with the motor running. It is possible to know the motor electric data (stator/rotor resistance, stator inductance). Regarding the characteristic data of the drive, the serial number, firmware version and motor control version are available. For the complete list see paragraph 7.2.

5.15 Modbus® Commands

The Power+ drive only uses Registers (16 bit), not boolean variables (coils). The Modbus® functions implemented are:

Function number	Function name
03 (0x03)	Holding register reading
04 (0x04)	Input register reading
06 (0x06)	Single register writing

The Modbus® exceptions supported are:

- exception 1: function not supported;
- exception 2: address not accepted;
- exception 3: value not accepted;
- exception 6: device occupied.

6 PROTECTIONS

Protections functions exist that intervene to prevent:

- 1) mechanical resonances;
- 2) drive overtemperature.

6.1 Skip frequency

It may be necessary to avoid particular frequencies in some systems due to mechanical resonance problems. Using the following parameters it is possible to fix the limits of the frequency area to be avoided for the frequency set point. If the frequency set point assumes a value within the area, the effective set point is blocked at values $f_c - B/2$ or $f_c + B/2$, depending whether the frequency is increasing or decreasing.

Mod. add.	Description	Def.	Min	Max	U.M.	R/W
10	Skip frequency: set	0	0	5000	0.1Hz	R/W
11	Skip frequency: band	0	0	5000	0.1Hz	R/W

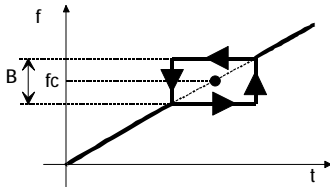

Key			
fc	Skip frequency: set	B	Skip frequency: band
t	Time	f	Frequency

Note: if the set point is outside the area defined by the set and the band, traversing the prohibited area takes place with normal acceleration and deceleration.

6.2 Automatic reduction of the switching frequency

On increasing switching frequency, motor noise decreases, but the heat to be dissipated increases and therefore, also the temperature of the drive. The switching frequency set is used on start-up and can be gradually decreased automatically if the temperature of the drive reaches high values, in a way to prevent the drive overtemperature alarm. If successively the temperature of the drive is within the typical values, the switching frequency gradually returns to the initial value. Among the reading-only variables, it is possible to display the effective switching frequency.

Mod. add.	Description	Def.	Min	Max	U.M.	R/W
24	Switching frequency 0 = 4kHz; 1 = 6kHz; 2 = 8kHz	0	0	2	-	R/W
25	Switching frequency derating 0/1 = no/yes	0	0	1	-	R/W
124	Operating switching frequency 0=4kHz, 1=6kHz, 2=8kHz	0	0	2	-	R

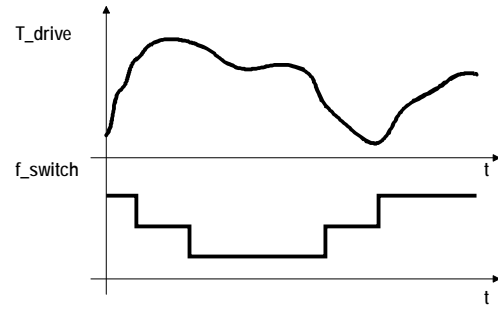

Key			
T_drive	Drive temperature	t	time
f_switch	switching frequency		

6.3 Automatic reduction of motor speed

It is possible to prevent the drive overtemperature alarm also using the automatic motor speed reduction function. Decreasing motor speed corresponds to decreasing the output power of the drive and therefore the heat to be dissipated. See the following figure. To activate the function, set the "Speed reduction mode" parameter at a value >0, which becomes the differential (DT) in order to determine the temperature threshold (T_{th-DT}). When this is exceeded, the speed set point is forced to minimum, corresponding to the "Minimum output frequency" parameter. If after a certain period of time, the temperature of the drive drops below the value T_{th-2DT} , the set point gradually returns to the requested value. If the differential is set at zero, the function is disabled.

Mod. add.	Description	Def.	Min	Max	U.M.	R/W
9	Speed derating mode 0 = function disabled	0	0	10	°C	R/W

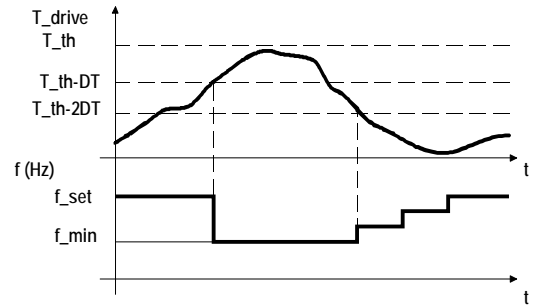

Key			
t	Time	DT	Differential for automatic speed decrease function
f_set	Frequency set point	t_drive	Drive temperature
T_th	Over-heating alarm threshold	f_min	Out frequency min

7 PARAMETERS TABLE

- NOTE:**
- the values of some parameters are expressed in tenths, hundredths, thousandths of the unit of measurement. For commodity, in this case the equivalent corresponding value in the standard unit of measurement is indicated at the side in brackets;
 - Y/N = YES/NO
 - all parameters and commands are accessible in reading and writing (R/W), the status variables are reading only (R). The identification is by address. If register identification is to be used, use the following formula: register = address+1

ModBus® address	Parameter	Def	Min	Max	U.M.	R/W	Description	Applicable for			Cannot be modified
								PM	AC vect.	AC V/f	
0	Motor control mode 0 = PM brushless motor 1 = asynchronous motor with vectorial control 2 = asynchronous motor with V/f control	0	0	2	-	R/W	Sets the type of motor and control.	Y	Y	Y	Y
1	Motor base frequency	500 (50.0Hz)	0	5000 (500.0Hz)	0.1Hz	R/W	Sets the motor base frequency (electric). For asynchronous motors (both vectorial and V/f control) the value can normally be found on the motor technical plate. For motors with permanent magnets (PM) it is suggested to set it at values indicated by CAREL.	Y	Y	Y	Y
2	Motor base voltage	230/400	25	250/500	V	R/W	Sets the phase-phase rated voltage (corresponding to the motor base frequency). For asynchronous motors (both vectorial and V/f control) the value can normally be found on the motor technical plate (depending on the type of triangle/delta connection). For motors with permanent magnets (PM) it is suggested to set it at values indicated by CAREL.	Y	Y	Y	Y
3	Motor rated current	Rat. Curr. drive output	(*)	(**)	0.1A	R/W	Sets the motor rated current. It is also the reference for motor overload protection (*T up to 150% of the rated current for 1 minute). For asynchronous motors (both vectorial and V/f control) the value can normally be found on the motor technical plate. For motors with permanent magnets (PM) it is suggested to set it at maximum motor current (normally corresponding to maximum electric frequency). For asynchronous motors with V/f control, only set the current threshold for overload protection. For PM brushless and asynchronous motors with vectorial control, the parameter establishes the maximum supplied current value. If to turn at a given speed, the motor requires a higher current than that set here, the drive limits the current with consequent speed reduction to a value consistent with the current supplied.	Y	Y	Y	Y

(*) Motor rated current : Min: PSD0*1440*: 36(3.6A); PSD0*2240*: 56(5.6A); PSD0*1020*: 0; PSD0*1620*: 0.

(**) Motor rated current : Max: PSD0*1440*: 180(18.0A); PSD0*2240*: 225(22.5A); PSD0*1020*: 105(10.5A); PSD0*1620*: 160(16.0A).

ModBus® address	Description	Def	Min	Max	U.M.	R/W	Description	Applicable for			Cannot be modified if drive is in RUN
								PM	AC vect.	AC V/f	
4	Motor power factor (cos(φ))	100(1.00)	0/50 (0.5)	100(1.00)	-	R/W	Sets the motor power factor (cos(φ)). For motors with permanent magnets (PM) it is suggested that the value is set at 100 (1.00). For asynchronous motors with vectorial control, the value can usually be found on the motor technical plate, set at 0 if the power factor is unknown.	N	Y	N	Y
5	maximum output current	1000 (100.0%)	0	2000 (200.0%)	%Motor rated current	R/W	If the control envisions, it is possible to supply the motor with current that can reach double the rated one, considering that the resulting current will be limited by the maximum value that can be supplied by the drive. A larger current than that supplied by the "Rated current" parameter can be applied for a limited period of time, after which the "Motor overload" alarm occurs. The threshold beyond which the alarm is activated corresponds to functioning at 150% of the rated current for 1 minute.	Y	Y	N	N
6	Maximum output frequency	0	0	5000(500.0Hz)	0.1Hz	R/W	Sets the drive maximum output frequency (electric)	Y	Y	Y	N
7	Minimum output frequency	0	0	5000(500.0Hz)	0.1Hz	R/W	Sets the drive minimum output frequency (electric)	Y	Y	Y	N
8	Reverse speed enable 0/1 = no/yes	0	0	1	-	R/W	Enables the run command also in anti-clockwise direction	Y	Y	Y	N
9	Speed derating mode 0 = function disabled	0	0	10	°C	R/W	The function allows to automatically reduce the speed depending on the temperature of the drive. If enabled, the value 3 is recommended (see par. 6.3).	Y	Y	Y	N
10	Skip frequency: set	0	0	5000(500.0Hz)	0.1Hz	R/W	Sets the prohibited frequencies interval set. See par. 6.1	Y	Y	Y	N
11	Skip frequency: band	0	0	5000(500.0Hz)	0.1Hz	R/W	Sets the prohibited frequencies interval band. See par. 6.1	Y	Y	Y	N
12	Speed profile: frequency 1	0	0	5000(500.0Hz)	0.1Hz	R/W	Frequency 1 of the speed profile	Y	Y	Y	N
13	Speed profile: frequency 2	0	0	5000(500.0Hz)	0.1Hz	R/W	Frequency 2 of the speed profile	Y	Y	Y	N
14	Speed profile: frequency 3	0	0	5000(500.0Hz)	0.1Hz	R/W	Frequency 3 of the speed profile	Y	Y	Y	N
15	Speed profile: acceleration 1	60(6.0Hz/s)	0	500(50.0Hz/s)	0.1Hz/s	R/W	Acceleration 1 of the speed profile	Y	Y	Y	N
16	Speed profile: acceleration 2	60(6.0Hz/s)	0	500(50.0Hz/s)	0.1Hz/s	R/W	Acceleration 2 of the speed profile	Y	Y	Y	N
17	Speed profile: acceleration 3	60(6.0Hz/s)	0	500(50.0Hz/s)	0.1Hz/s	R/W	Acceleration 3 of the speed profile	Y	Y	Y	N
18	Speed profile: acceleration 4	60(6.0Hz/s)	0	500(50.0Hz/s)	0.1Hz/s	R/W	Acceleration 4 of the speed profile	Y	Y	Y	N
19	Speed profile: delay 1	0	0	600	s	R/W	Delay 1 of the speed profile	Y	Y	Y	N
20	Speed profile: delay 2	0	0	600	s	R/W	Delay 2 of the speed profile	Y	Y	Y	N
21	Speed profile: delay 3	0	0	600	s	R/W	Delay 3 of the speed profile	Y	Y	Y	N

ModBus® address	Description	Def	Min	Max	U.M.	R/W	Description	Applicable for			Cannot be modified if drive is in RUN		
								PM	AC vect.	AC V/f			
22	Speed profile: execution method (2 bit parameter)	3	0	3	-	R/W	See par. 5.6	Y	Y	Y	N		
	bit											meaning	0/1
	0											delay execution	always/only once at every start-up
1	force frequency 2	no/at start-up											
23	Speed profile: deceleration	60(6.0Hz/s)	0	500(50.0Hz/s)	0.1Hz/s	R/W	Set the frequency deceleration	Y	Y	Y	N		
24	Switching frequency 0 = 4kHz; 1 = 6kHz; 2 = 8kHz	0	0	2	-	R/W	Sets the switching frequency of the IGBT. See par. 6.2.	Y	Y	Y	N		
25	Switching frequency derating 0/1 = no/yes	0	0	1	-	R/W	The function allows to automatically decrease the PWM switching frequency on the basis of drive temperature	Y	Y	Y	N		
26	Relay configuration 0: drive in alarm 1: fan control 2: drive overtemperature alarm 3: motor overtemperature alarm 4: motor overload alarm 5: overvoltage alarm 6: undervoltage alarm 7: speed derating in progress 8: motor run	0	0	8	-	R/W	Selects the event associated to closure of the relay contact	Y	Y	Y	N		
27	Motor overtemperature alarm (PTC) enable 0/1=no/yes	0	0	1	-	R/W	Enables the motor overtemperature alarm, which occurs if the PTC input sees a resistance of > 600 ohm at its ends for the time set at the "Motor overtemperature alarm delay" parameter	Y	Y	Y	N		
28	Motor overtemperature alarm delay	0	0	600	s	R/W	Sets the time after which the "Motor overtemperature" alarm occurs	Y	Y	Y	N		
29	Data communication fault 0 = alarm disabled	0	0	600	s	R/W	Sets the time after which the "Data communication fault" alarm occurs if the communication with the Master is interrupted (only if the motor is running)	Y	Y	Y	N		
30	Data communication baudrate 0 = 9600 bit/s; 1 = 19200 bit/s	1	0	1	-	R/W	Sets the Modbus® communication baudrate. The modified value becomes effective only after a reset or successive switch-on of the drive.	Y	Y	Y	N		
31	Data communication parity 0 = none; 1 = even; 2 = odd	0	0	2	-	R/W	Set the data communication parity (and therefore stop bit) for communication. The modified value becomes effective only after a reset or successive switch-on of the drive.	Y	Y	Y	N		

ModBus® address	Description	Def	Min	Max	U.M.	R/W	Description	Applicable for			Cannot be modified if drive is in RUN
								PM	AC vect.	AC V/f	
32	Base address	1	1	232	-	R/W	Sets the drive base address. The drive network address is included in the "Base address"... "Base address" +15 interval, according to the position of the dip-switches. The modified value becomes effective only after a reset or successive switch-on of the drive.	Y	Y	Y	N
33	Stop mode 0 = ramp; 1 = coast	1	0	1	-	R/W	Sets the drive stop mode, following a stop command.	Y	Y	Y	N
34	Flying restart 0/1=no/yes	0	0	1	-	R/W	Enables speed hitching, whenever the RUN command takes place with motor rotating.	N	Y	Y	N
35	V/f boost voltage	0	0	250(25.0%)	% Motor base voltage	R/W	Sets the voltage applied at frequency 0. See par. 5.10.	N	N	Y	Y
36	V/f frequency adjustment	0	0	1000 (100.0%)	%Motor base frequency	R/W	Sets the frequency adjustment to adapt the V/f curve.	N	N	Y	Y
37	V/f voltage adjustment	0	0	1000 (100.0%)	%Motor base voltage	R/W	Sets the voltage adjustment to adapt the V/f curve.	N	N	Y	Y
38	RESERVED (DO NOT MODIFY)	0	-	-	-	R/W		-	-	-	-
39	RESERVED (DO NOT MODIFY)	0	-	-	-	R/W		-	-	-	-
40	RESERVED (DO NOT MODIFY)	0	-	-	-	R/W		-	-	-	-
41	RESERVED (DO NOT MODIFY)	0	-	-	-	R/W		-	-	-	-
42	RESERVED (DO NOT MODIFY)	0	-	-	-	R/W		-	-	-	-
43	RESERVED (DO NOT MODIFY)	0	-	-	-	R/W		-	-	-	-
44	RESERVED (DO NOT MODIFY)	0	-	-	-	R/W		-	-	-	-
45	Motor magnetizing current	0	0	Rated output current	0.1A	R/W	Sets the motor magnetizing current	N	Y	N	N
46	Stator resistance	0	0	38500 (38.500Ω)	mΩ	R/W	Sets the stator resistance	Y	Y	N	N
47	Rotor resistance	0	0	38500 (38.500Ω)	mΩ	R/W	Sets the rotor resistance	N	Y	N	N
48	Stator inductance/Ld	0	0	6130(613.0mH)	0.1mH	R/W	Sets the motor stator inductance (Ld component for motors with permanent magnets (PM), Ls for asynchronous motors)	Y	Y	N	N

ModBus® address	Description	Def	Min	Max	U.M.	R/W	Description	Applicable for			Cannot be modified if drive is in RUN
								PM	PM	PM	
49	Leakage factor	0	0	250(0.25)	-	R/W	Sets the motor dispersion factor (0=stator and rotor perfectly coupled. Set at 100(=0.1)	N	Y	N	N
50	Lq inductance	0	0	6130(613.0mH)	0.1mH	R/W	Sets the inductance component Lq per for the motor with permanent magnets (PM)	Y	N	N	N
51	Magnetizing time	100(0.1s)	0	30000 (30.000s)	ms	R/W	Sets the application time of the "Starting current" or of the "Voltage boost"	Y	Y	Y	Y
52	RESERVED (DO NOT MODIFY)	0	0	1	-	R/W		-	-	-	-
53	Regeneration current limit	1000 (100.0%)	0	2000 (200.0%)	%Motor rated current	R/W	Sets the regeneration current limit. Set the "Maximum motor current" value	Y	Y	N	N
54	Overvoltage control current limit	100 (10.0%)	0	2000 (200.0%)	%Rated current motor	R/W	Sets the current limit to use for the prevention of overvoltage. In the case of overvoltage, the drive accelerates the motor slightly to prevent the alarm.	Y	Y	N	N
55	Speed loop: Kp	250 (25.0%)	0	2000 (200.0%)	%	R/W	Expressed in tenths of percentage of the unit gain	Y	Y	N	N
56	Speed loop: Ti	500(0.5s)	1(0.001s)	1000(1s)	ms	R/W		Y	Y	N	N
57	Starting current	1000(100.0%)	0	1000(100.0%)	%	R/W	The current applied at start-up depends on the type of motor:	Y	Y	N	N
							<table border="1"> <tr> <td>Motor with permanent magnets</td> <td>Asynchronous motor vectorial control</td> </tr> <tr> <td>Starting current * Rated current</td> <td>(100% + starting current)* Magnetizing current</td> </tr> </table>				
Motor with permanent magnets	Asynchronous motor vectorial control										
Starting current * Rated current	(100% + starting current)* Magnetizing current										
58	Max frequency for starting current	0	0	1000(100.0%)	%Frequency rated motor	R/W	Sets the frequency up to which the current applied at start-up is applied	Y	Y	N	N
59	RESERVED (DO NOT MODIFY)	0	-	-	-	R/W		-	-	-	-

7.1 Commands

ModBus® address	Parameter	Def	Min	Max	U.M.	R/W	Description	Applicable for		
								PM	AC vect.	AC V/f
100	Run/stop (2 bit parameter)	-	0	3	-	R	Clockwise and anti-clockwise run and Stop commands	Y	Y	Y
	bit meaning									
	0 0/1= stop/run									
101	Reset (3 bit parameter)	-	0	7	-	R	The bits must be taken back to zero after the reset control has been given (1)	Y	Y	Y
	bit meaning									
	0 1= alarms reset and updating of communication parameters									
	1 1= parameters reset at default values									
102	Frequency set point	-	Minimum output frequency	Maximum output frequency	0.1Hz	R	Sets the desired output frequency, the direction of rotation is given by bit1 of the "Run/stop" command.	Y	Y	Y
	Autotuning 0/1= not active/start	-	0	1	-	R				

7.2 Status variables

ModBus® address	Parameter	Def	Min	Max	U.M.	R/W	Description	Applicable for		
								PM	AC vect.	AC V/f
104	Drive status 0 = Stop; 1 = Run; 2 = Alarm	-	0	2	-	R	Shows the status of the drive	Y	Y	Y
105	Alarm code	-	0	19	-	R	See the "Alarms" chapter	Y	Y	Y
	0 No alarm	10 CPU error								
	1 Overcurrent	11 Parameter default								
	2 Motor overload	12 DCbus ripple								
	3 Overvoltage	13 Data communication fault								
	4 Undervoltage	14 Drive thermistor fault								
	5 Drive overtemperature	15 Autotuning fault								
	6 Drive undertemperature	16 Drive disabled (STO input open)								
	7 Overcurrent HW	17 Motor phase fault								
	8 Motor overtemperature	18 Internal fan fault								
9 RESERVED	19 Speed fault									

ModBus® address	Parameter	Def	Min	Max	U.M.	R/W	Description	Applicable for		
								PM	AC	AC V/f
106	Status register (15 bit parameter)	-	-	-	-	R	Shows the details of the drive status	Y	Y	Y
	bit meaning 0/1									
	0	safety input status Safety Torque Off (STO)			drive enabled/disabled					
	1	relay status			off/on					
	2	motor thermistor status			normal/overtemperature functioning					
	3	undervoltage			0/1 = normal/undervoltage functioning					
	4	fan status			0/1 =OFF/ON					
	5	switching frequency reduction			0/1 = no/yes					
	6	RESERVED			-					
	7	autotuning status			no/yes					
	8	motor overload status			no/yes					
	9	power supply status			OK/loss of a power supply phase (L1)					
	10	RESERVED			-					
11	drive in alarm			no/yes						
12...15	RESERVED			-						
107	Speed register (15 bit parameter)	-	-	-	-	R	Bit 2 on switch-on is forced to 1. With the Reset command (bit2) the flag can be reset at 0. In this way it is possible to control if the drive has been switched off and back on again.	Y	Y	Y
	bit meaning 0/1									
	0	speed profile completed at least once			yes/ no					
	1	automatic reduction of motor speed			no /yes					
	2	flag verifies drive switch off and back on			no/ yes					
3...15	RESERVED			-						
108	Motor frequency	-	-	-	0.1Hz	R	Motor equivalent frequency Normally equal to "Post-ramp frequency set point", except in situations with current limitation, in which case it is equal to the estimated value of the "Rotor frequency"	Y	Y	Y
109	Motor current	-	-	-	0.1A	R	Actual current of the motor	Y	Y	Y
110	Motor power	-	-	-	0.01kW	R	Current power of the motor	Y	Y	Y
111	Motor voltage	-	-	-	V	R	Voltage applied to the motor	Y	Y	Y
112	RESERVED	-	-	-	-	R	-	-	-	-
113	DC bus voltage	-	-	-	V	R		Y	Y	Y
114	Drive temperature	-	-	-	°C	R		Y	Y	Y
115	Switch-on time	-	-	-	hour	R	Drive life time	Y	Y	Y
116	Drive run time	-	-	-	hour	R	Drive switch-on time with motor running	Y	Y	Y

ModBus® address	Parameter	Def	Min	Max	U.M.	R/W	Description	Applicable for		
								PM	AC vect.	AC V/f
117	Drive run time from last alarm	-	-	-	hour	R		Y	Y	Y
118	kWh meter	-	-	-	0.1kWh	R	Total energy supplied to the motor: when it reaches 10,000 (1000kWh), it goes back to zero and the counter is increased in MWh.	Y	Y	Y
119	MWh meter	-	-	-	MWh	R		Y	Y	Y
120	Network address	-	1	247	-	R	Drive network address	Y	Y	Y
121	Dip-switch address	-	0	15	-	R	Network address set by the drive dip-switches	Y	Y	Y
122	Modbus® communication error	-	-	-	-	R	Show additional information regarding communication error	Y	Y	Y
123	Modbus® error counter	-	-	-	-	R		Y	Y	Y
124	Operating switching frequency 0 = 4kHz, 1 = 6kHz, 2 = 8kHz	-	-	-	-	R		Y	Y	Y
125	Pre-ramp frequency set point	-	-	-	0.1Hz	R	Shows the internal set point for the output frequency before the acceleration/deceleration ramps	Y	Y	Y
126	Post-ramp frequency set point	-	-	-	0.1Hz	R	Shows the internal set point for the output frequency after the acceleration/deceleration ramps	Y	Y	Y
127	RESERVED	-	-	-	-	R		-	-	-
128	RESERVED	-	-	-	-	R		-	-	-
129	RESERVED	-	-	-	-	R		-	-	-
130	RESERVED	-	-	-	-	R		-	-	-
131	RESERVED	-	-	-	-	R		-	-	-
132	Rotor frequency	-	-	-	0.1Hz	R	Shows the estimated rotor frequency, expressed in equivalent electric frequency for motors with permanent magnetic (PM) and asynchronous motors with vectorial control. Shows the drive output frequency for asynchronous motors with V/f control	Y	Y	Y
133	RESERVED	-	-	-	-	R		Y	Y	Y
134	DCbus ripple	-	-	-	V	R	Shows the voltage variation (ripple) in the DC bus	Y	Y	Y
135	RESERVED	-	-	-	-	R		Y	Y	Y
136	RESERVED	-	-	-	-	R		Y	Y	Y
137	Alarm 1	-	-	-	-	R	Shows the last alarm in queue	Y	Y	Y
138	Alarm 2	-	-	-	-	R	Shows the second to last alarm in queue	Y	Y	Y
139	Alarm 3	-	-	-	-	R	Shows the third to last alarm in queue	Y	Y	Y
140	Alarm 4	-	-	-	-	R	Shows the fourth to last alarm in queue	Y	Y	Y
141	Bootloader release	-	-	-	-	R		Y	Y	Y
142	Firmware release	-	-	-	-	R		Y	Y	Y

ModBus® address	Parameter	Def	Min	Max	U.M.	R/W	Description	Applicable for		
								PM	AC vect.	AC V/f
143	Firmware checksum	-	-	-	-	R		Y	Y	Y
144	Motor control release	-	-	-	-	R		Y	Y	Y
145	Serial number 1	-	-	-	-	R		Y	Y	Y
146	Serial number 2	-	-	-	-	R		Y	Y	Y
147	Serial number 3	-	-	-	-	R		Y	Y	Y
148	Serial number 4	-	-	-	-	R		Y	Y	Y
149	Hardware Identification 2010: PSD0*102** 2016: PSD0*162** 4014: PSD0*144** 4022: PSD0*224**	-	-	-	-	R		Y	Y	Y

8 ALARMS

8.1 Types of alarm

There are two types of alarm:

- drive malfunctioning alarms;
- motor malfunctioning alarms.

Among the status variables it is possible to check the presence of Modbus® communication alarms. All alarms stop the motor and must be restored using the reset control:

Pr.101 = 1

followed by the command:

Pr.101 = 0

to go back to the start situation.

8.2 Alarms log

The most recent 4 alarms are memorised in a FIFO type alarms queue. The last alarm memorised is visible in the Alarm 1 status variable.

Mod bus	Description	Def	Min	Max	U.M.	R/W
137	Alarm 1	-	-	-	-	R
138	Alarm 2	-	-	-	-	R
139	Alarm 3	-	-	-	-	R
140	Alarm 4	-	-	-	-	R

Mod bus®	Description	Def	Min	Max	U.M.	R/W
101	Reset (3 bit parameter)	0	0	7	-	R/W
	bit meaning					
	0 1= alarms reset and updating of communication parameters					
	1 1= parameters reset at default values					
	2 1= reset flag check drive switch on and switch off (see speed register, bit2)					

8.3 Alarms table

The alarm code is given in the Alarm 1...4 parameters and in the alarm code parameter (Modbus®=105)

Alarm code	Description	Relay alarm	Reset	Possible cause	Solutions
0	No alarm	-	-	-	-
1	Overcurrent	(*)	reset command	The drive has detected a current supplied that is too high due to: - sudden strong load increase; - acceleration that is too high; - inadequate motor.	Control the load, the dimension of the motor and the cables. Decrease acceleration.
2	Motor overload	(*)	reset command	The current supplied has exceeded the rated current over the maximum time accepted	
3	Overvoltage	(*)	reset command	The DC voltage of the intermediate circuit has exceeded the limits envisioned due to: - deceleration that is too high; - high over-voltage peaks on the power supply network.	Decrease deceleration.
4	Undervoltage	(*)	reset command	The DC voltage of the intermediate circuit is below the limits envisioned due to: - insufficient power supply voltage; - fault inside the drive.	In the event of temporary cut-off of the power supply, reset the alarm and re-start the drive. Control the power supply voltage.
5	Drive overtemperature	(*)	reset command	The temperature inside the drive has exceeded the maximum level allowed.	Control that the quantity and flow of cooling air are regular. Control that there is not dust in the heat sink. Control the environment temperature. Ensure that the switching frequency is not too high with respect to the environment temperature and the motor load.
6	Drive undertemperature	(*)	reset command	The temperature inside the drive has exceeded the minimum level allowed.	
7	Overcurrent HW	(*)	reset command	The drive has detected a current supplied that is too high due to: - sudden strong load increase; - motor cables short circuit; - inadequate motor.	

Alarm code	Breakdown	Alarm relay	Reset	Possible cause	Solutions
8	Motor overtemperature	(*)	reset command	The temperature detected by the PTC thermistor corresponds to a resistance > 600 ohm.	Reduce the motor load. Check motor cooling.
9	RESERVED				
10	CPU error	(*)	reset command	Loss of data in memory	
11	Parameter default	(*)	reset command		
12	DCbus ripple	(*)	reset command	Input motor phase	Control the input power supply phases to the drive
13	Data communication fault	(*)	reset command		Check the serial connection. Switch the drive off and back on again.
14	Drive thermistor fault	(*)	reset command		Call for assistance
15	Autotuning fault	(*)	reset command		
16	Drive disabled (STO input open)	(*)	close input		
17	Motor phase fault	(*)		Cable disconnected	Control the connections of the motor cable
18	Internal fan fault				Call for assistance
19	Speed fault	(*)			Switch the drive off and back on again and check that the parameters are correct. Check the motor load.

(*) Depends on the configuration parameter

8.4 Modbus® communication error code

A value is memorised in the code (Modbus® = 122) that indicates both the trend of the communication and the status of the drive. These errors are not memorised in the alarms log and do not cause the activation of the alarm relay.

Modbus® communication error	Description	Possible cause
2	Address not valid	Attempt to read or write a parameter that is not in the correct address
3	Data not valid	Parameter value out of range
4	Drive command not valid	Master command not recognised by the drive
12	Drive operation not valid	- Attempt to reset parameters at the factory value while the drive is in RUN - Drive undervoltage

8.5 Motor overtemperature

The intervention of the overtemperature alarm depends on the setting of the enabling and delay parameters. It is possible to connect a PTC thermistor or a thermostat to the digital input set-up. See the Electrical installation paragraph.

Mod bus®	Description	Def	Min	Max	U.M.	R/W
27	Motor overtemperature alarm (PTC) enable 0/1=no/yes	0	0	1	-	R/W
28	Motor overtemperature alarm delay	0	0	600	s	R/W

8.6 Serial communication interruption

The interrupted communication alarm must be enabled by setting the "Data communication fault" at a value >0.

It is recommended to enable this alarm otherwise, if the data communication fault occurs with the drive/motor running, stop can no longer be commanded.

Mod bus®	Description	Def	Min	Max	U.M.	R/W
29	Data communication fault 0 = alarm disabled	0	0	600	s	R/W

 **Important:** the alarm is only active if the drive is in the Run status.

8.7 Alarms signal with relay

The relay can be used by configuring it in a way that signals the status of the drive in alarm or a specific alarm. See paragraph 5.2.

9 TECHNICAL SPECIFICATIONS

Environmental conditions	Storage temperature	-40T60°C	
	Operating temperature	-20T60°C	
	Humidity	95% rH non-condensing	
	Altitude	Maximum allowed: 4000 m above sea level Up to 1000 m a.s.l. without declassing Declassing of maximum output current: 1% /100 m	
Power supply	Input voltage (depending on the model)	200 to 240 V ± 10%, 50 to 60 Hz, 1~ (model PSD0***2**) 380 to 480 V ± 10%, 50 to 60 Hz, 3~ (model PSD0***4**)	
Motor output	Output voltage	0...Tensione di ingresso	
	Output frequency	0...500 Hz	
	Maximum length	25m – shielded cable	
	Switching frequency	4, 6, 8 kHz	
Functions	Protection functions	Drive:	short-circuit, overcurrent, earth fault, overvoltage and undervoltage, overtemperature
		Motor:	overtemperature and overload
		System:	Safety Torque OFF input, communication failure
	Frequency resolution	0,1 Hz	
Control unit	Each drive must be connected in the network via Modbus® to a CAREL pCO controller or third party control unit that manages the drive based on Master/Slave logic.		
Inputs	1 motor protector input	PTC temp. probe or voltage-free contact max source current 10 mA, max. length 25 m	
	1 "Safety Torque Off" digital input	1 contact at 24 Vac/Vdc ± 20%: typical input current 5 mA, maximum length 25 m	
Outputs	1 relay	Programmable output, voltage-free contact: 240 Vac, 5 A	
	24Vdc auxiliary power supply	Double insulation, precision 2%, 50 mA max	
Interface	Serial data connection	RS485, Modbus® protocol, maximum transmissionspeed 19200 bit/s. Receiver input resistance 12kohm typical (1 unit-load, that is 1/32 of total bus load)	
	Maximum length	100 m – shielded cable	
Casing index of protection	IP20 (front panel) IP44 for heat sink (installation with heat sink outside of panel)		
Conformity to standards	CE conformity		
	Low voltage directive	73/23/EEC EN 61800-5-1: Adjustable speed electrical power drive systems. Safety requirements. Electrical, thermal and energy.	
		2004/108/EEC EN 61800-3, 2a e.: Adjustable speed electrical power drive systems. EMC requirements and specific test methods. Category C2 and C3. EN 55011: Industrial, scientific and medical (ISM) radiofrequency equipment. Electromagnetic disturbance characteristics. Limits and methods of measurement	
	Electromagnetic compatibility directive	EN61000-3-12: Electromagnetic compatibility (EMC) Part 3-12: Limits - Limits for harmonic currents produced by equipment connected to public low-voltage systems with input current > 16 A and ≤ 75 A per phase. For three-phase models, conformity depends on: • use of the optional DC choke specified; • public mains power supply with short-circuit power Ssc ≥ 1.9MVA at the point of connection (see table 4 of the standard with Rsc ≥ 120)	
		Maximum short-circuit current allowed at the drive terminals (IEC60439-1)	
		100kA	

9.1 Rated current values

The table below shows the rated input and output current values, as well as the specifications for sizing the cables (cross-section, maximum length) and the fuses. The values refer to an operating temperature of 60 °C and a switching frequency of 4 kHz, unless otherwise specified.

Single-phase models, 200 to 240 Vac

Model	Rated input current (A)	Fuse or type B circuit breaker (A)	Power cable cross-section (mm ²)	Rated output current (A)	Max. heat dissipation (W)	Minimum motor cable cross-section (mm ²)	Maximum motor cable length (m)
PSD0*10200	20	32	4	10,5	-	2,5	25
PSD0*16200	30	40	6	16	-	4	25

Three-phase models, 380 to 480 Vac

Model	Rated input current (A)	Fuse or type B circuit breaker (A)	Power cable cross-section (mm ²)	Rated output current (A)	Max. heat dissipation (W)	Minimum motor cable cross-section (mm ²)	Maximum motor cable length (m)
PSD0*14400	22	32	4	14,5 18(50°C)	250 300	4	25
PSD0*22400	28	32	6	22,5	400	6	25

10 APPENDIX

10.1 Conversion formulas

$RPS = F / (P / 2)$	$RPS = RPM / 60$
$RPM = (F \times 60) / (P / 2)$	$RPM = RPS \times 60$
$F = RPS \times (P / 2)$	$F = (RPM \times (P / 2)) / 60$

Key:

F	frequency (Hz) of the voltage and current applied to motor
RPS	revolution per second of motor shaft (rotor)
RPM	revolution per minute of motor shaft (rotor)
P	number of poles of motor (always an even number)
P/2	number of polar couples of motor



Note: In AC motors (asynchronous induction motor) RPS and RPM derived from previous formulas are not the actual value because of the intrinsic rotor "slip". The actual values is always lower than calculated RPS and RPM values, and the difference increase with the load. The RPM actual value is motor dependent and it is usually specified by manufacturer at nominal load.

10.2 Conversion table

F (Hz)	2 poles		4 poles		6 poles		8 poles		10 poles	
	RPS	RPM	RPS	RPM	RPS	RPM	RPS	RPM	RPS	RPM
10	10	600	5	300	3,3	200	2,5	150	2	120
20	20	1200	10	600	6,7	400	5	300	4	240
30	30	1800	15	900	10	600	7,5	450	6	360
40	40	2400	20	1200	13,3	800	10	600	8	480
50	50	3000	25	1500	16,7	1000	12,5	750	10	600
60	60	3600	30	1800	20	1200	15	900	12	720
70	70	4200	35	2100	23,3	1400	17,5	1050	14	840
80	80	4800	40	2400	26,7	1600	20	1200	16	960
90	90	5400	45	2700	30	1800	22,5	1350	18	1080
100	100	6000	50	3000	33,3	2000	25	1500	20	1200
110	110	6600	55	3300	36,7	2200	27,5	1650	22	1320
120	120	7200	60	3600	40	2400	30	1800	24	1440
130	130	7800	65	3900	43,3	2600	32,5	1950	26	1560
140	140	8400	70	4200	46,7	2800	35	2100	28	1680
150	150	9000	75	4500	50	3000	37,5	2250	30	1800
160	160	9600	80	4800	53,3	3200	40	2400	32	1920
170	170	10200	85	5100	56,7	3400	42,5	2550	34	2040
180	180	10800	90	5400	60	3600	45	2700	36	2160
190	190	11400	95	5700	63,3	3800	47,5	2850	38	2280
200	200	12000	100	6000	66,7	4000	50	3000	40	2400
210	210	12600	105	6300	70	4200	52,5	3150	42	2520
220	220	13200	110	6600	73,3	4400	55	3300	44	2640
230	230	13800	115	6900	76,7	4600	57,5	3450	46	2760
240	240	14400	120	7200	80	4800	60	3600	48	2880
250	250	15000	125	7500	83,3	5000	62,5	3750	50	3000
260	260	15600	130	7800	86,7	5200	65	3900	52	3120
270	270	16200	135	8100	90	5400	67,5	4050	54	3240
280	280	16800	140	8400	93,3	5600	70	4200	56	3360
290	290	17400	145	8700	96,7	5800	72,5	4350	58	3480
300	300	18000	150	9000	100	6000	75	4500	60	3600
310	310	18600	155	9300	103,3	6200	77,5	4650	62	3720
320	320	19200	160	9600	106,7	6400	80	4800	64	3840
330	330	19800	165	9900	110	6600	82,5	4950	66	3960
340	340	20400	170	10200	113,3	6800	85	5100	68	4080
350	350	21000	175	10500	116,7	7000	87,5	5250	70	4200
360	360	21600	180	10800	120	7200	90	5400	72	4320
370	370	22200	185	11100	123,3	7400	92,5	5550	74	4440
380	380	22800	190	11400	126,7	7600	95	5700	76	4560
390	390	23400	195	11700	130	7800	97,5	5850	78	4680
400	400	24000	200	12000	133,3	8000	100	6000	80	4800

Headquarters

CAREL S.p.A.

Via dell'Industria, 11 - 35020 Brugine - Padova (Italy)
Tel. (+39) 0499 716611 - Fax (+39) 0499 716600
carel@carel.com - www.carel.com

Subsidiaries:

CAREL Asia Ltd

Rm. 11, 8/F., Shatin Galleria,
18 Shan Mei St., Fotan, Shatin - Hong Kong
Tel. (+852) 2693 6223 - Fax: (+852) 2693 6199
e-mail: sales@carel-asia.com - www.carelhk.com

CAREL Australia Pty Ltd

PO Box 6809, Silverwater B.C. N.S.W. 1811
Unit 37, 11-21 Underwood Rd Homebush N.S.W. 2140
Tel: (+612) 8762 9200 - Fax: (+612) 9764 6933
e-mail: sales@carel.com.au - www.carel.com.au

CAREL China - CAREL Electronic (Suzhou) Co. Ltd.

No. 26, 369 Lushan Road,
Suzhou City, Jiangsu Province,
215129 P.R. of China
Tel: (+865) 12 66628098 - Fax: (+865) 12 66626631
e-mail: sales@carel-china.com - www.carel-china.com

CAREL Deutschland GmbH

Am Spielacker, 34, 63571 Gelnhausen (Germany)
Tel. (+49) 6051 96290 - Fax (+49) 6051 962924
e-mail: info@carel.de - www.carel.de

CAREL France Sas

32, rue du Champ Dolin - 69800 Saint Priest, France
Tel. (+33) 472 47 88 88 - Fax (+33) 478 90 08 08
e-mail: carelfrance@carelfrance.fr - www.carelfrance.fr

CAREL Ibérica

Automatización y control ATROL S.L.
Comte Borrell, 15 - 08015 Barcelona
Tel. (+34) 933 298 700 - Fax. (+34) 933 298 700

DELEGACIÓN CENTRO

Edificio Burgosol C/Comunidad de Madrid, 35 bis, Oficina 47
28230 Las Rozas - MADRID
tel.(+34) 91 637 59 66 - Fax: (+34) 91 637 32 07
e-mail: atrol@atrol.es - www.carel.es

CAREL Sud America Ltda

Avenida Dourado, 587 - Cep. 13.280-000 Vinhedo - São Paulo (Brasil)
Tel (+55) 19 38 26 25 65 - Fax (+55) 19 38 26 25 54
e-mail: carelsudamerica@carel.com.br - www.carel.com.br

CAREL U.K. Ltd

Unit 6, Windsor Park Industrial Estate, 50 Windsor Avenue
Merton SW19 2TJ, London (United Kingdom)
Tel. (+44) 208 545 9580 - Fax (+44) 208 543 8018
e-mail: careluk@careluk.co.uk - www.careluk.co.uk

CAREL U.S.A. L.L.C

385 South Oak Street
Manheim, PA 17545, Pennsylvania (USA)
Tel. (+1) 717-664-0500 - Fax (+1) 717-664-0449
e-mail: sales@carelusa.com - www.carelusa.com

All trademarks hereby referenced are
the property of their respective owners.
CAREL is a registered trademark of
CAREL S.p.A. in Italy and/or other countries.

© CAREL S.p.A. 2008 all rights reserved

CAREL reserves the right to modify the features of its products
without prior notice.

www.carel.com

PRELIMINARY

Affiliates:

CAREL Korea Co. Ltd.

A-901, Chung Ang Circ. Complex
1258 Kuro Bon-Dong, Kuro-KU,
Seoul-KOREA
Tel: (+82) 02 2068 8001
Fax: (+82) 02 2068 8005
e-mail: info@carel.co.kr - www.carel.co.kr

CAREL Ireland

FarrahVale Controls & Electronics Ltd
28E Ashbourne Business Centre
County Meath - IRELAND
Tel: (+353) 1 8353745
Fax: (+353) 1 8353681
www.carel.com - info@carel.ie

CAREL Spol (Czech and Slovakia) s.r.o. Prazska 298

250 01 Brandys nad Labem, Czech Republic.
Tel: (+420) 326 377 729
Fax: (+420) 326 377 730
e-mail: carel@carel-cz.cz - www.carel-cz.cz

CAREL Thailand Co., Ltd.

444 4th Floor OlympiaThai Building, Ratchadapisek Road,
Samsennok, Huaykwang, Bangkok 10310 Thailand
Tel: (+66) 2 513 5610
Fax: (+66) 2 513 5611
e-mail: info@carel.co.th - www.carel.co.th

CAREL Turkey

CFM Sogutma ve Otomasyon San. Tic. LTD
1201 Sok. No: 13/Z 21
Izmir - TURKEY
Tel: (+90) 232 4590888
Fax: (+90) 232 4593435
www.cfmsoгутma.com - info@cfmsogutma.com

CAREL si riserva la possibilità di apportare modif che o cambiamenti ai propri prodotti senza alcun preavviso.

Power+ +0300050EN - rel. 2.1 - preliminary- 21.06.2010